

Genuine Front spoiler Installation main point book

This each time the Toyota genuine "front spoiler" the buying とき receiving, thank you for. This book is stated concerning the installation main point when the "front spoiler" is installed.

品番

Item Number	0 8 1 5 4 - 4 7 0 2 0
-------------	-----------------------

構成部品

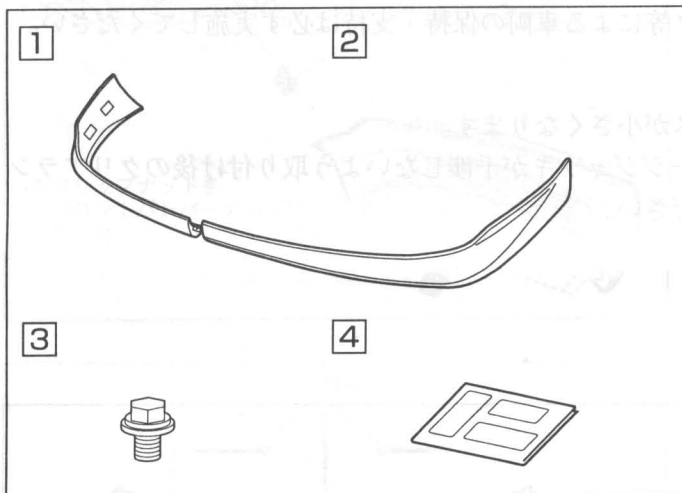

No.	Item Name	Item Number	Qty
1	Front spoiler -RH	—	1
2	Front spoiler -LH	—	1
3	Bolt	91653-40612	8
4	Main point book	—	1

補給品番



Item Number	Item Name	Component
08154-47025	Substance set (RH)	Substance (body) 3、4、Front protect mall (black/grey)
08154-47026	Substance set (LH)	Substance (body) 3、4、Front protect mall (black/grey)
08154-47024	Front protect mall	4、Front protect mall (black/grey)
08154-47029	フィッティングキット	3、4

取付に必要な工具等

General tool, air drill (ϕ 3 ϕ 7 ϕ 9), marking-off pin, masking tape and adhesion tape, rag, vinyl seat

取付上の注意事項

1. The case of installation, when we would like to protecting by all means and, you know convenient thing in the below-mentioned indication is stated in context.

 Note	Notice the 琢 the つ is in the Mori loving and accident the り, to do the wound, the car is damaged 懸 is some possibility.
 Advice	スピ - D - working, when, receiving knowing, it states the fact that you want.

2. After the フロントフォグランプ equipped car separating the negative cable of the vehicle battery, please work.

3. Other than indicating in this book, please do not remove the vehicle part. In addition, taking expectation of the vehicle part it dies and encounters, there is no loss and confusion of タッピングスクリュー and volt/bolt and the nuts rearranging every sea urchin part, as not mistaken for the occasion where it reconstructs please consider.

4. For the being hurt prevention which is in the midst of job, it prepares the vinyl seat, and the like installs and, job going by all means on that, is the < , T ≒ 1/4 N "r, -

5. Jacking-up/lifting raising the vehicle, when you work, the vehicle and following the jack/the lift, to the handling book please work safely. Please be sure to execute the retention support of the vehicle by the wheel stopper and the rigid rack etc.

At the time of the use of the garage jack: Clearance from the land becomes small depending upon the front spoiler. Way the jack the front spoiler and the garage jack do not interfere the occasion where it knocks down, the clear run after the installing

取付概要

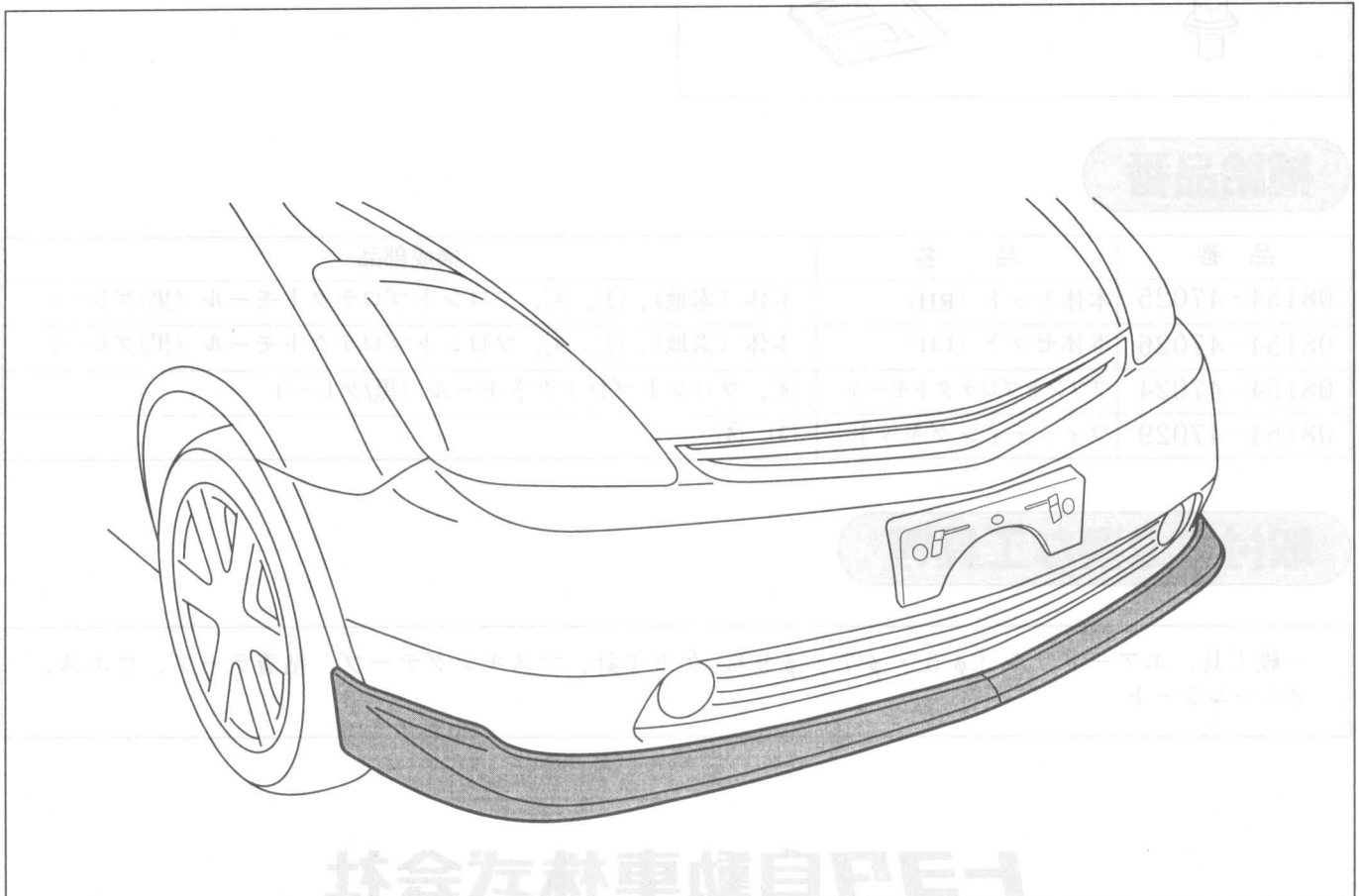

取付要領

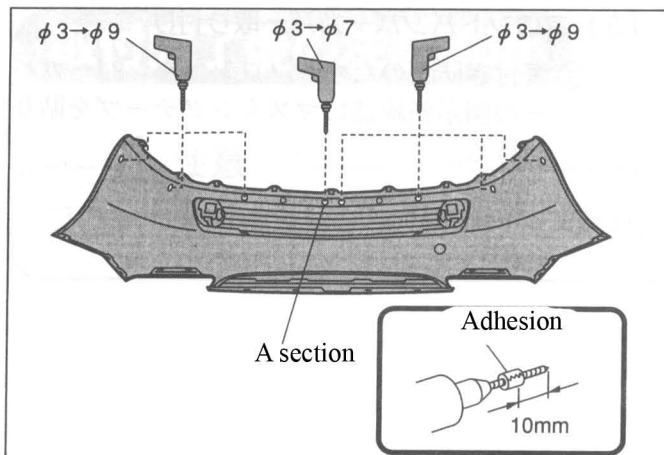
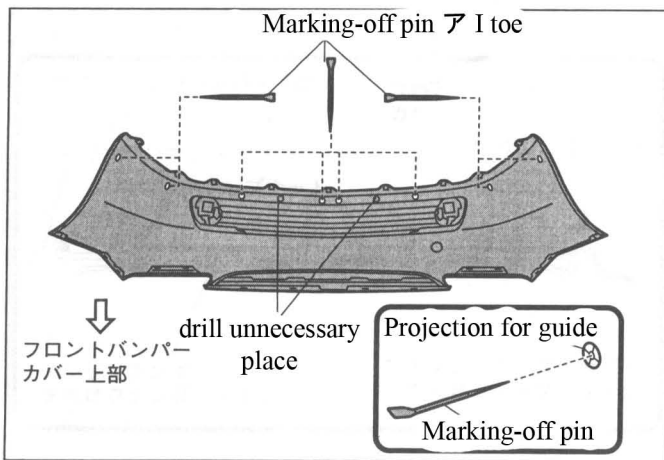
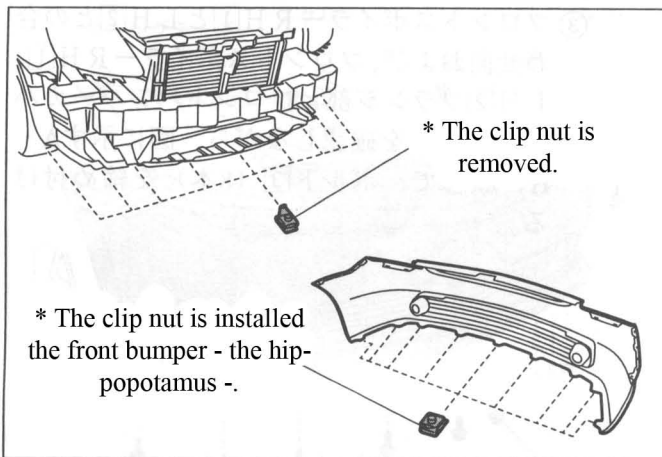
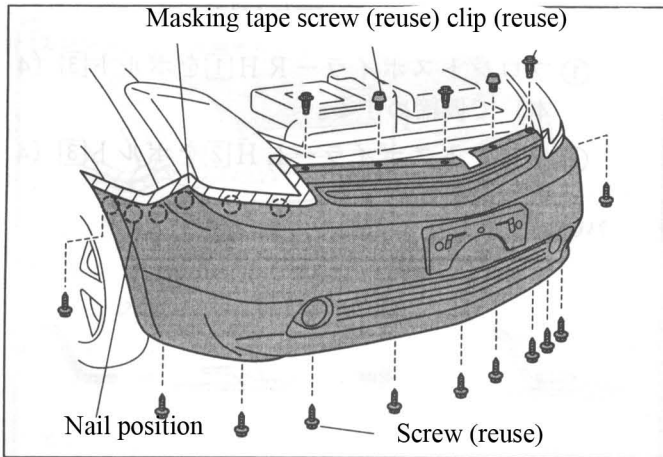

1. As for taking the vehicle part sushi

(1) front pan pas - power pas - as for taking sushi

For being hurt prevention, in oblique line section in figure [masukingutepu]It sticks.

Clip of front bumper cover top

(3) and screw (2) taking You remove.

Front bumper cover lower part and both ends

The screw (11) you remove.

Fitting (12 places) the nail is removed.

It cuts the connector of X フロントフォグランプ and separates. (Only front fog lamp equipped car)

Clip nut (9) [enjinandakaba]

And fender liner dry rubbing

Like removing and figure [hurontobanpakaba]

You install.



Advice

Because taking the sushi is reuses the vehicle part, be mixed up it does not lose, the sea

2. Installation job

(1) front pan pas - power pas - processing

Using the marking-off pin, the front van parka

Center of projection (8 places) for guide of bar reverse side The through hole is bored.



Advice

The drill unnecessary place which is shown in the figure (2 places), in order not to do drill job, please note.

② As in figure drill ($\phi 3$. $\phi 7$. $\phi 9$)

In order to become stopper, the adhesion tape is wound, attaching [ke] [ru].

③ Using the air drill ($\phi 3$), [hurontobanpakaba]

From reverse side in through hole prepared hole (You open 8 places).

④ Using the air drill ($\phi 7$), illustration A This hole is

bored through the prepared hole (1 places) of the section.

⑤ Using the air drill ($\phi 9$), remainder

This hole is bored through the prepared hole (7 places).

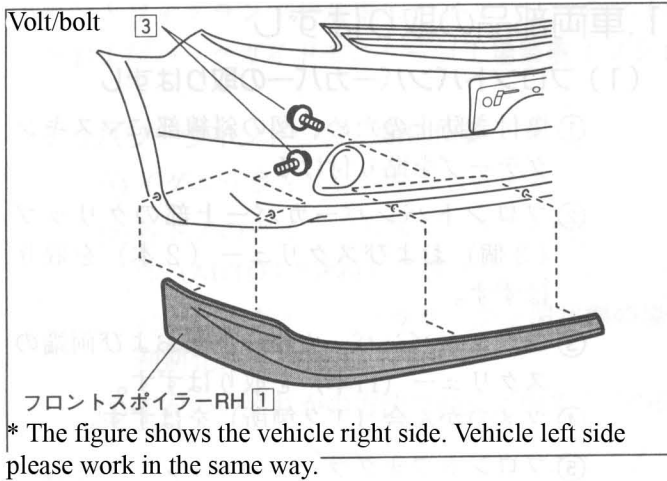

(2) front spoiler - installation

- ① Front spoiler RH time volt/bolt time (4 Book) So it tightens temporarily.
- ② Front spoiler LH time volt/bolt time (4 Book) So it tightens temporarily.

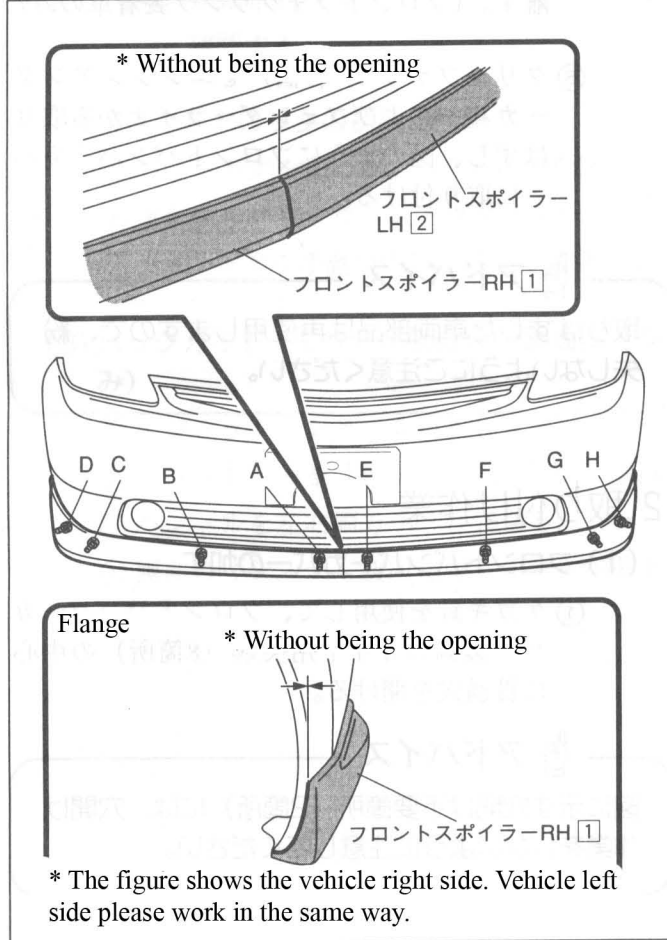
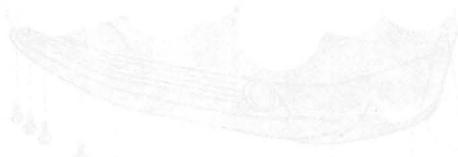

- ③ Combination of front spoiler RH time and LH time [wa] [se] aspect and front spoiler RH time, LH time flange and [hurontobanpakaba] While verifying adjusting, A~ which it shows in the figure In the order of H, volt/bolt time (8) tightening [ru].



(3) [hurontopanpa] - power pas - installation

- ① For being hurt prevention, [hurontobanpakaba] In illustration oblique line section pasting masking tape You attach.

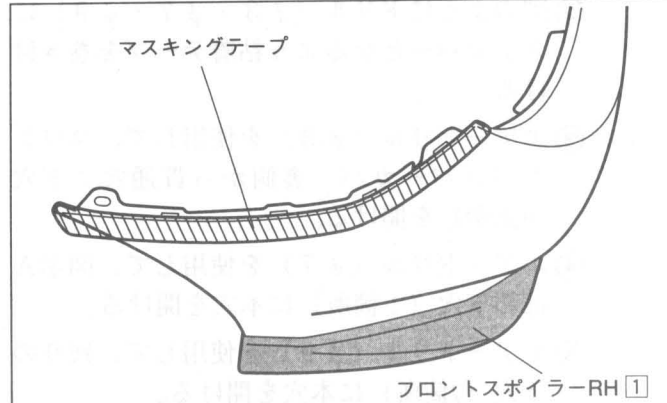

* The figure shows the vehicle right side. Vehicle left side please work in the same way.

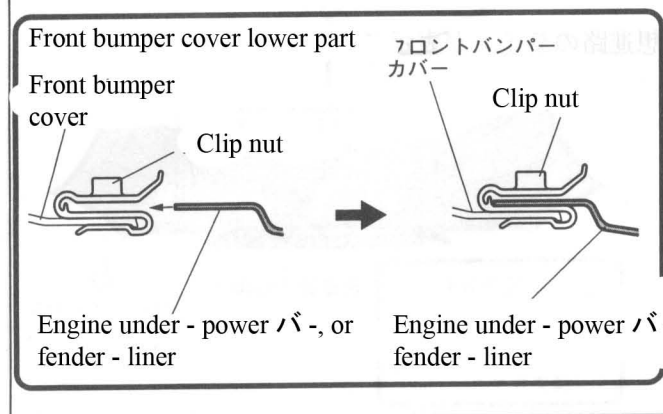
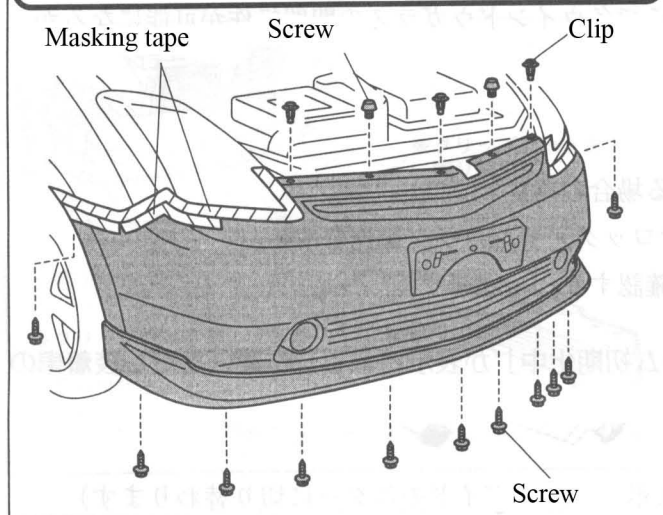
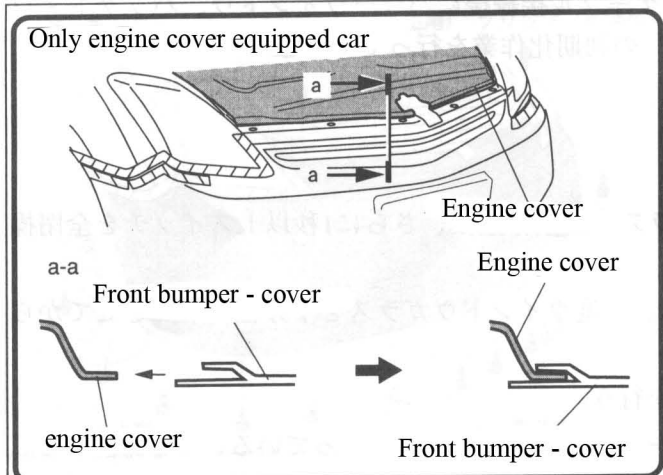

- ② Connecting the connector of [hurontohuoguranpu] It does. (Only front fog lamp equipped car)
- ③ Front bumper cover installation to vehicle [hu]

アドバイス

エンジンカバー装着車のみ
 図のようにフロントバンパーカバーをエンジンカバーに差し込んでください。

- ④ On front bumper cover top clip (3) and screw (2) taking You attach.
- ⑤ You installed in front bumper cover lower part In clip nut [enjinandakaba] Or [huendaraina] is inserted.
- ⑥ The masking tape which is stuck by being hurt prevention
- ⑦ In front bumper cover lower part and both ends The screw (11) you install.

アドバイス

プロテクトモールとフロントバンパーカバーに隙間がある場合は、隙間がある箇所のボルト③を緩め、フロントスポイラーの取付位置を下げて、隙間を修正後、ボルト③を締め付けてください。

取付完了後の注意事項



Note

The front spoiler - please verify that it is installed securely in the vehicle.

復元後の初期化作業

As for the front fog lamp equipped car, the power window, バックドアロック and the back guide monitor (factory installing option) please do initialization job after the negative cable junction of the battery.

(1) [pawa] - initialization job of window

- ① The ignition key is turned to ON.

UP operating the window switch of each door, the glass after the full closing stop, furthermore the switch of 1 second or more full closing virtue

The work (AUTOUP retention) it operates.

However, when the window glass is full closing state, after - half falling the degree window glass

Initialization job is done.

- ③ You verify the completion of initialization job with the below-mentioned each method.

- You verify that the indicator (mark) of each window switch from blinking becomes illumination.
- With the power window master switch of the driver's seat does opening and closing operation of each window glass become possible?

You verify.

(2) initialization job of pack door lock

- ① The back door is closed. (When back door opens only.)
- ② Lock/unlocking operation is done with the power window master switch of the driver's seat.
- ③ You verify whether it becomes possible to open the back door by hand.

(3) [patsukugaidomo] two [ta] - initialization ("during of system initializing" is indicated in the picture,) job (however the equipped car

Seeing)



The n ignition key is turned to ON.

- ② The shifter is put in "the R" range. (Indication of picture to back guide monitor it changes)

- ③ The steering wheel to left and right both - is turned in the cup.

- ④ Indication "in the midst of system initializing" of the picture goes out, you verify that the line of expectation course is indicated.

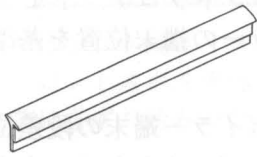
取付部品

①	品名	個数
	① Front protect mall (black/grey)	各1
	② Volt/bolt	4

- The substance of the front spoiler for replenishment has become the not yet paint item. Therefore because of protect mall sticking strength definite preservation, following to the below-mentioned contents, doing sticking the protect mall in the masking when painting, and after the painting it is the < , V4 ハ

加工要領

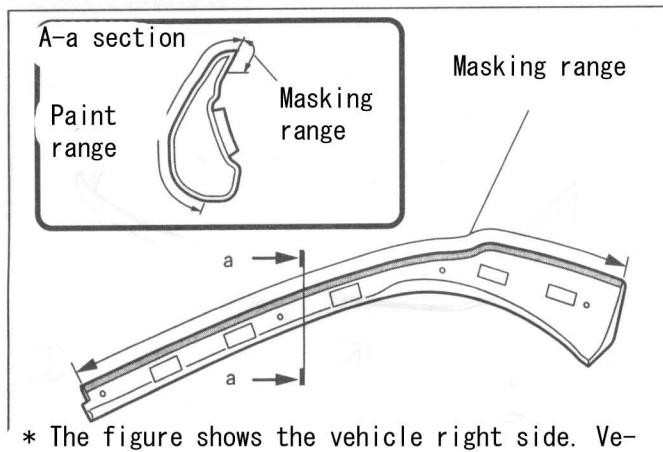

* The figure shows the vehicle right side. Vehicle left side please work in the same way.

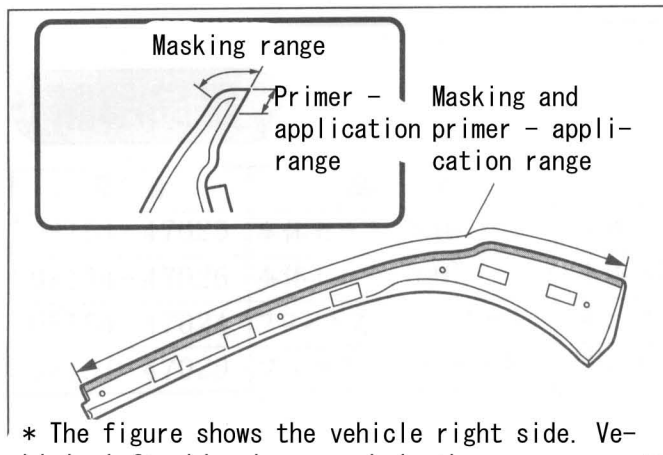

* The figure shows the vehicle right side. Vehicle left side please work in the same way.

1. Masking main point when painting
(1) the illustration front professional tech トモール sticking section of the front spoiler the masking is done.

(2) after the primer processing for paint, a - a section the coating equipment is done in reference.

2. フロント プ ロラル テクトモ - pasting attaching-
け main point of ル (1) the illustration painted surface of the front spoiler マスキング is done.

(2) the primer (the Sumitomo 3M primer K - 520) it applies to the illustration section of the front spoiler uniformly, makes dry.

アドバイス

プライマーが塗装面に付着すると塗装を痛めます。

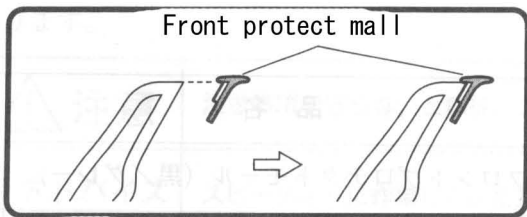

Front protect mall

Front protect mall①
Sticking direction

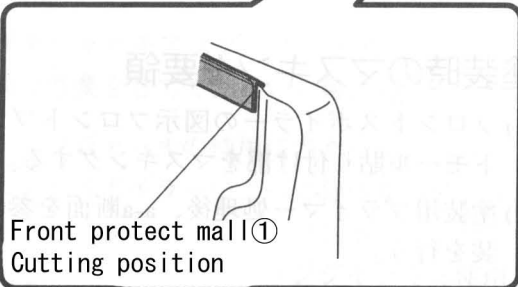
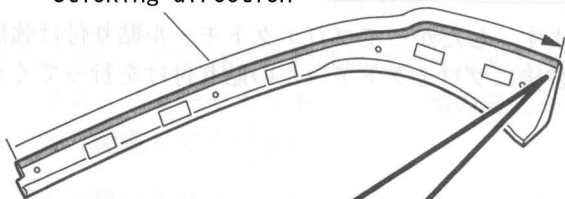

Front protect mall①
Cutting position

* The figure shows the vehicle right side. Vehicle left side please work in the same way.

(3) before the repairing the front protect which is installed

Front protect mall of the same color as mall① (Black or gray) is prepared.

(4) with main point in figure, front protect mall ①

Terminal position of front spoiler in standard center

(4) the combination わせて, surplus amount of the front protect mall is cut to difference in level position of the front spoiler terminal in the figure.

(5) the front protect mall which is stuck 49N [is bonded above 5kgfl.

修理工程

