



## Efficiency Test Method for Electric Vehicle Chargers

**Kieldsen, Andreas; Thingvad, Andreas; Martinenas, Sergejus; Sørensen, Thomas Meier**

*Published in:*

Proceedings of EVS29 - International Battery, Hybrid and Fuel Cell Electric Vehicle Symposium

*Publication date:*

2016

*Document Version*

Peer reviewed version

[Link back to DTU Orbit](#)

*Citation (APA):*

Kieldsen, A., Thingvad, A., Martinenas, S., & Sørensen, T. M. (2016). Efficiency Test Method for Electric Vehicle Chargers. In *Proceedings of EVS29 - International Battery, Hybrid and Fuel Cell Electric Vehicle Symposium*

---

### General rights

Copyright and moral rights for the publications made accessible in the public portal are retained by the authors and/or other copyright owners and it is a condition of accessing publications that users recognise and abide by the legal requirements associated with these rights.

- Users may download and print one copy of any publication from the public portal for the purpose of private study or research.
- You may not further distribute the material or use it for any profit-making activity or commercial gain
- You may freely distribute the URL identifying the publication in the public portal

If you believe that this document breaches copyright please contact us providing details, and we will remove access to the work immediately and investigate your claim.

# Efficiency Test Method for Electric Vehicle Chargers

Andreas Kiildsen (s091681@student.dtu.dk), Andreas Thingvad (s113573@student.dtu.dk),  
Sergejus Martinenas and Thomas Meier Sørensen

*Department of Electrical Engineering, Technical University of Denmark - DTU, Kgs. Lyngby, Denmark*

---

## Abstract

This paper investigates different methods for measuring the charger efficiency of mass produced electric vehicles (EVs), in order to compare the different models. The consumers have low attention to the loss in the charger though the impact on the driving cost is high. It is not a high priority area for the Original Equipment Manufacturer (OEM), which means the cost of the power converter equipment is minimised. The internal wiring and the composition of components within an EV is different for each OEM and model, hence a unified test method is needed in order to compare results across different vehicles. A unified method for testing the efficiency of the charger in EVs, without direct access to the component, is presented. The method is validated through extensive tests of the models Renault Zoe, Nissan LEAF and Peugeot iOn. The results show a loss between 15 % and 40 %, which is far above the state of the art power converters. This is an unnecessary high consumption of electrical energy during charging, which not only affects the consumer financially, but also creates unnecessary load on the grid.

*Keywords: EV, On-board, Charger, Efficiency, Energy consumption.*

---

## 1 Introduction

The increasing environmental concern in the public has caused a large increase of the sales of EVs, as a sustainable way of transport. This is partly caused by public subsidies and the technical development [1].

Most EVs charge at 2.3 kW and 3.7 kW which is much higher than the power consumption of an individual household, this is why EVs, from a grid perspective, is considered as a large load increase [2]. Intelligent control of the charging is in these days heavily discussed as a matter of making the EVs a grid-supporting unit by performing frequency control or peak shaving [3, 4]. There is however less focus on the efficiency of the charging, though reducing the loss in the charger would reduce the time the EVs would be a load to the grid. A large loss in the charger is an economic burden for the consumer, an unnecessary large load for the grid and limits the ability to perform services for the grid. The internal power loss is a limitation to the degree EVs can be integrated in the grid to perform ancillary services.

A significant amount of energy is transferred while charging an EV, the efficiency should therefore be one of the main concerns when designing a charger. Other concerns are small volume, light weight, reliability, low electromagnetic interference and low current and voltage ripples. Apart from the automotive constraints it has to be made of low cost components to keep the total cost of the EV down.

Most EVs on the market are able to charge at a range of 6-16 A and individual models like Renault Zoe has a range of 6-63 A. A large range results in a reduction in the efficiency. A power converter with an efficiency of 95 % have a decrease in efficiency of 10 % when operating at half the nominal power, which EVs often do [5, 6]. This paper shows that the aforementioned effect is present in the tested EVs and that the loss is closely related to the charge range.

A typical reason for a high loss in a converter is when well-dimensioned components are discarded for cheaper models in order to keep the retail price down. Under-dimensioned components cause higher heat dissipation that makes cooling necessary, which is an additional power consumption. The OEM can reduce cost of the components without consequences as it is impossible for the consumer to compare the efficiency of the vehicle with other models on the market. The manufacturer specifies the battery capacity and a drivable range that can be achieved on a full battery, but the amount of electrical energy

that is needed to fully charge the battery is not specified.

## 2 Principle of charging

The efficiency of an EV charger depends on the efficiency of various internal components. Electrical power is converted several times; from the AC supply to the DC main lithium ion EV battery (MAIN), from the MAIN to the AC motor and from the MAIN to the conventional auxiliary lead-acid car battery (AUX).

### 2.1 Charging cycle

When charging an EV, the Electric Vehicle Supply Equipment (EVSE) limits the maximum drawn current by communicating the limit to the EV via a PWM signal. The EV then sets the load so it is charging with the maximum current for most of the charge. When the State of Charge (SOC) is near 100 % the EV reduce the current to be able to level the potential of the individual cells in the MAIN and achieve 100 % SOC. Fig.1 shows how Renault Zoe reduce the power consumption earlier when charging higher powers from a SOC of approximate 80 %. That means that the SOC has to be sufficiently low to find the charger efficiency when charging with high powers. Fig.2 shows the cell voltages of the 88 battery cells in the

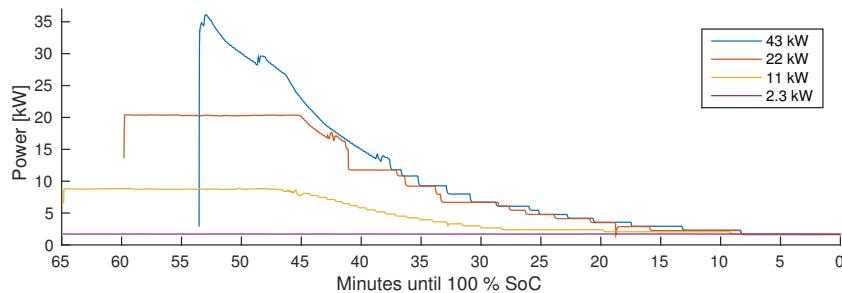

Figure 1: Charging power for Renault ZoE for the first 80 minutes when the starting SOC is 80 %.

MAIN on Peugeot iOn for a complete charge from 0-100 % SOC. The battery cells mainly change the voltage level when the SOC is low. The battery cells have an internal voltage difference of 0.2 V when the MAIN is as discharged as possible, and they are almost the same level in the end of the charge when the Battery Management System (BMS) have levelled them. It is necessary to level the cells to achieve 100 % SOC. Fig.2 shows that the BMS makes sure that the MAIN is never fully discharged and levels the cells close to the maximum capacity such that the MAIN never experiences large voltage changes.

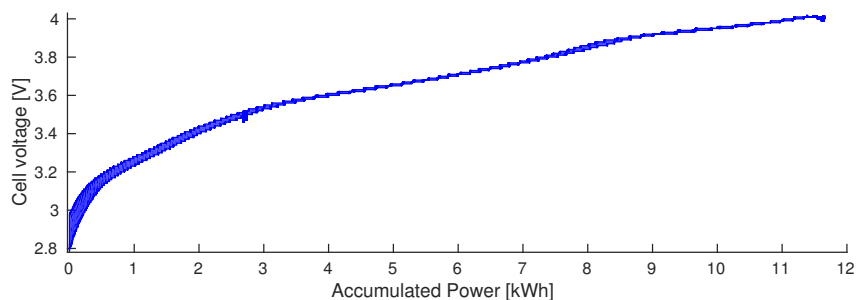

Figure 2: Voltage of the individual battery cells vs. the accumulated energy delivered to the MAIN for a full charge of Peugeot iOn with 10 A

When knowing the temperature and voltage of the individual cells the BMS can greatly expand the lifetime of the MAIN by avoiding over charge and under charge [7]. Note that the fully charged battery contains 12 kWh, though a new Peugeot iOn has a specified battery capacity of 16 kWh. This capacity degradation is caused by the age and number of charge/discharge cycles and demonstrates that the charger efficiency cannot be found by comparing the energy delivered by the EVSE to the specified battery capacity.

## 2.2 Power flow

The components regarding the flow of power in an EV is shown in Fig.3. The high voltage bus and everything connected to it, is isolated and not accessible for reasons of safety and operation reliability. It is considered as a grey box since the overall functionality is known, but the internal wiring and components are unknown.

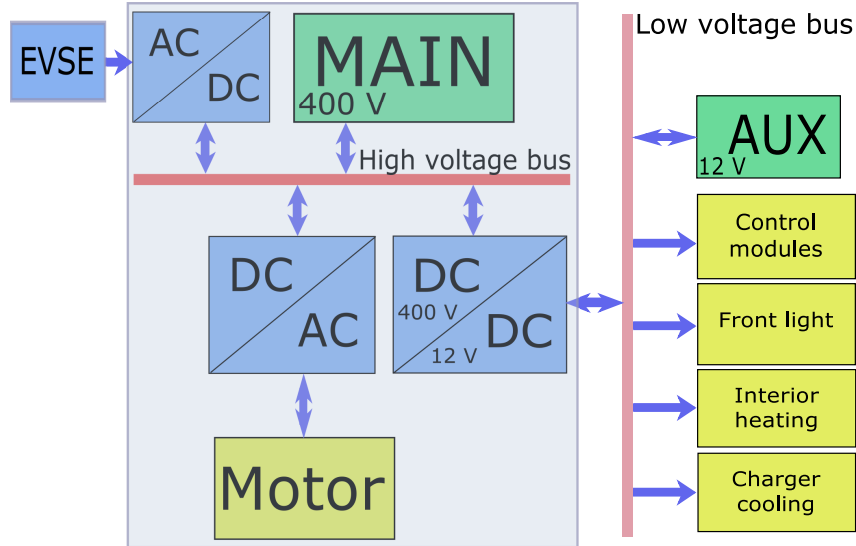

Figure 3: EV power flow block diagram

There are several components connected to the low voltage bus and not all are known, but the connection from the DC/DC converter to the low voltage bus goes through the main fuse to the AUX so the combined power consumption can be measured.

## 3 Methodology

The internal charger in an EV, is a power converter containing a rectifier and a boost converter to change the 230 V AC to DC with the same voltage level as the MAIN, which typically is 250 – 400 V. To get a precise value of the efficiency of the AC/DC converter, it would be optimal to get physical access and measure the power on both sides of the converter, during charging. To avoid breaking the warranty of the EV, it is necessary to use a measuring method that facilitates the available access to the EVs components. This paper describes a method to measure and calculate an estimate, without breaking the warranty and disassembling vital parts.

The test method is a unified way to measure the charging efficiency of all EVs. It was developed to test the charging efficiency on three popular EVs, as the only available method for all three models. The method is used on Peugeot iOn, Nissan LEAF and Renault Zoe, which all have different access to measuring points. The used EVs have driven 10-20.000 km and are tested while charging with standardised charging powers according to the IEC 62196 standard.

The three EVs in this test have different access to measuring points, which allows different ways to measure the efficiency of the charger. The different methods are first presented and described then the found efficiencies are compared and the uncertainties are analysed.

### 3.1 Method 1

The optimal method to calculate the efficiency of the charger is to measure the power on both sides (input and output). The output of the charger is only accessible on Peugeot iOn. The accessible measuring points for the iOn are shown on Fig.4. The grey box represent the same components as in Fig.3. The input to the charger is measuring point A and the output is point C. The efficiency is then calculated using equation 1.

$$\eta_1 = \frac{V_C \cdot I_C}{P_A} \cdot 100\% \quad (1)$$

The active power is measured by a power meter while the DC current and voltage are measured separately.

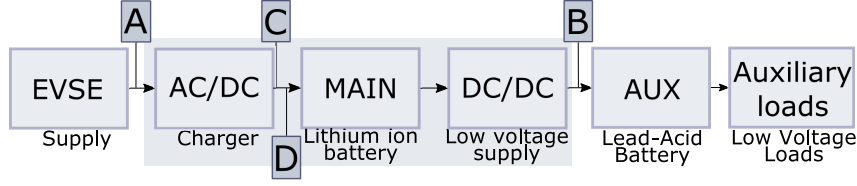

Figure 4: Measurement points on Peugeot iOn.

### 3.2 Method 2

All EVs have an internal measurement network that registers the current to and from the MAIN, the cell voltages and SOC amongst other things. These measurements are communicated through the Controller Area Network (CAN)-bus and can be logged and decoded using the EV data acquisition system presented in [8]. It is a data logger that can access the internal measurements of the EV by connecting to the On-Board Diagnostics (OBD) port and access the data. It is unknown how the different EVs measure and calculate the different quantities of the CAN-bus. For Peugeot iOn, where measurement point A, B and C are accessible, it is found that the CAN-bus shows the voltage and current to and from the MAIN, i.e. measure point D in Fig.4.

The power delivered to the MAIN is lower than the power from the charger because of the internal consumption during charging. The measurements from point D can be used to calculate an estimate of the loss in the charger when compared to the measurements of the power delivered from the EVSE, point A. The efficiency of the charger can, with the data from the CAN-bus, be found by equation 2.

$$\eta_2 = \frac{V_D \cdot I_D}{P_A} \cdot 100\% \quad (2)$$

This method is only used for verification and not as a primary measurement method because the CAN-bus has a specific identifier for each measurement, and these identifiers are initially unknown by the public. The measurements from the CAN-bus can only be accessed if the identifiers are known as the messages are non-standardised. The relevant CAN-bus identifiers are found by various enthusiasts for EVs such as Peugeot iOn and Nissan LEAF, but not for Renault Zoe. Even when the data can be decoded from the CAN-bus, it is unknown how it is measured and calculated. However, accurate measurements of the power flow into the MAIN is critical for the central controllers ability to estimate the MAIN health and the range at a certain speed.

### 3.3 Method 3

This unified method facilitates the available access of mass produced EVs, where the only measurement points are A and B, outside the grey box in Fig.5. It is assumed that the unmeasured losses in the grey area are similar for different models. The MAIN is discharged from 100-80 % SOC through the low voltage

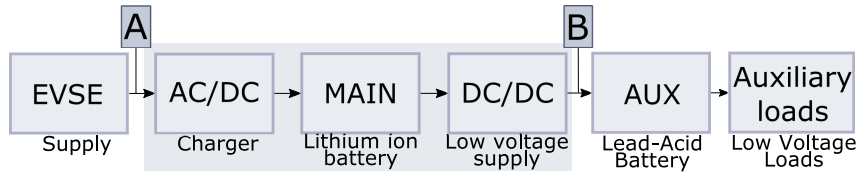

Figure 5: Block diagram of EV.

bus, seen in Fig.3, bus with a measured amount of energy ( $E_{B,discharge}$ ). The MAIN is then normally charged from 80-100 % SOC with a measured amount of energy ( $E_A$ ). During charging, controllers and cooling systems consume energy through the low voltage bus. This amount ( $E_{B,charge}$ ) is subtracted for a more exact estimate. Using equation 3 it is possible to calculate the efficiency of the grey box.

$$\eta_3 = \frac{E_{B,discharge}}{E_A - E_{B,charge}} \cdot 100\% \quad (3)$$

#### 3.3.1 Instruments and procedure

Point A is measured with DEIF MIC-2 power meter. The active power is used and it is logged with a sample rate of 1 second. At point B, a Hioki LR8402-20 Memory HiLogger are logging voltage and

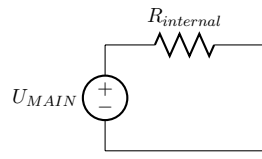

Figure 6: Thévenin equivalent MAIN as an ideal voltage source in series with an impedance.

current with a sample rate of 1 second.

Prior test: MAIN and AUX are at 100 % SOC, and all components are at a temperature of 19-22°C.

1. The EV is turned on. This activates the DC/DC converter that supplies the AUX. The high beam is enabled as an electrical load.
2. When the EV is discharged with a specified amount of energy, calculated as 20 % of the full capacity, the EV is turned off.
3. The charge cable from the EVSE is connected to the EV, and it start charging.
4. The BMS registers that the MAIN has reached 100 % SOC and stops the charging.

### 3.4 Uncertainties

#### 3.4.1 Loss in the battery

The loss in MAIN depends on the internal resistance of the individual cells in the batch. This resistance highly depends on the SOC, temperature, number of charging cycles, discharge current and internal electrochemical conditions such as ion mobility. The internal resistance means that a part of the power is converted into heat. A current source, such as the MAIN, with an internal resistance, can with regards to the Thévenin theorem be represented as a voltage source in series with an impedance, as seen in Fig.6. When the circuit is closed, the internal resistance cause a voltage drop. Knowing the voltage drop and current, it is possible to calculate the resistance. In the EV there is a voltage change when charging and discharging the MAIN. The internal resistance of the MAIN gives a good estimate of the loss of power and it is found for the Peugeot iOn. Fig.7 shows voltage, current and SOC of the MAIN for a test with method 3. The lower graph shows the SOC of the MAIN and demonstrates the concept of how the MAIN is discharged with a known amount of energy and then recharged to 100 % SOC again.

When the EV is turned off and the charger is connected, the MAIN voltage increases 2.5 V during an increase of current of 6.5 A. That means that there is an internal resistance of 0.38 Ω, which is quite small and only result in a heat dissipation of  $P_{loss} = I^2 \cdot R_{internal} = 7.2 W$ , when charging with 10 A 230 V. The internal resistance gives an impression of the MAIN health, but it is not constant as it depends

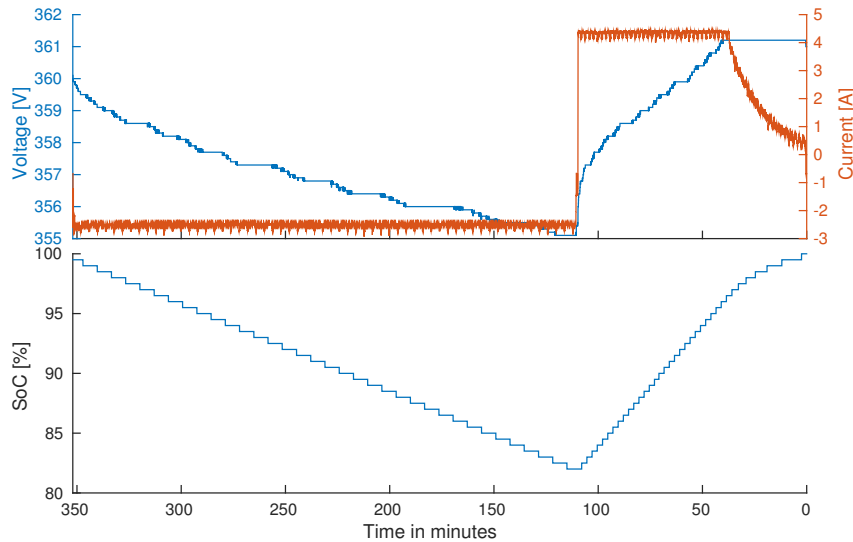

Figure 7: Voltage, current and SOC of MAIN from the CAN-bus during a discharge/charge cycle with 2.3 kW

on several parameters, which means that it will vary for each test. According to [10] the temperature and SOC is the most significant parameters. All tests are performed when the EV has been parked in a temperature controlled room for a few hours, so all components has a temperature of 19-22°C. All tests

are performed for the same SOC. The number of previous charging cycles and the charging pattern is an unknown factor, but it is the same for all tests on the specific EV.

### 3.4.2 Efficiency of the DC/DC converter

The power consumed by the low voltage side is depending on the amount of electrical equipment activated and can be above 1 kW, which results in an output current above 100 A. The power consumption can also be below 100 W and this vast interval makes it a design challenge to achieve a high efficiency. The nominal voltage of the low voltage side is 12 V but it ranges up to 14.5 V during charging. Depending of the EV model, the MAIN voltage ranges between 250 V and 400 V. The efficiency of the DC/DC converter is a part of the grey box and causes  $\eta_3$  to be a little less than  $\eta_1$ . For Peugeot iOn  $\eta_3$  is 2 % lower than  $\eta_1$  and that indicates that the power efficiency of the DC/DC converter is about 98 %.

### 3.4.3 Other components in the grey area

The EV supply most of the internal electronic loads on the low voltage bus via a DC/DC converter, but since the circuit diagram is detained by the OEM it is unknown whether some subsystems are supplied by an independent converter. Those subsystems could be the climate compressor or the MAIN cooling. All cooling appears to be supplied by the low voltage bus on Peugeot iOn.

The EV have an AC motor that is powered with a traction inverter module. The inverter is designed to be able to convert power of several hundreds kW. The power consumption of the inverter should be zero when the EV is in park mode, but it could have standby consumption as it might be energised when the EV is turned on to ensure a quick start-up. This consumption is an uncertainty in this test method as its magnitude is unknown.

Some EVs, such as Renault ZOE, activate the DC/DC converter when the lights are turned on and the test can be performed without activating the motor inverter, which should reduce the unknown consumption.

## 4 Results and discussion

### 4.1 Peugeot iOn

Fig. 8 shows the power flowing through the various measuring points at any second during charging. The legend order corresponds to the order of the graph, from top to bottom. The purple line (lowest graph) shows the power flow at measuring point B. It indicates a low continuous consumption of energy, presumably for internal computers in the BMS. The periodical trend in the consumption are also seen during discharge and is therefore assumed to be caused by the internal cooling. Measuring point D

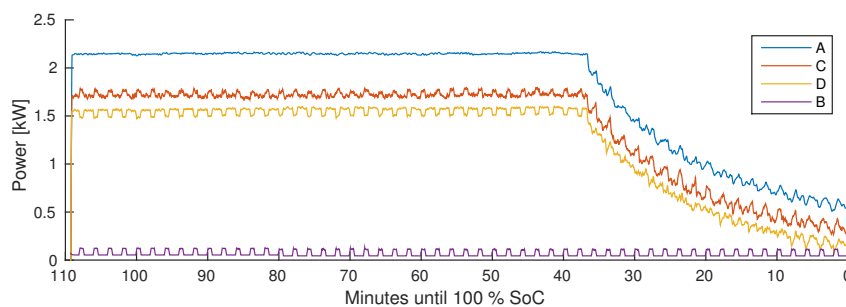

Figure 8: Power at various measuring points for Peugeot iOn during 2.3 kW charge.

(yellow graph), shows the EV's own measurements and are logged from the CAN-bus. As it is unknown which sensors are used and where they are placed, there is a gross uncertainty of relying on this data. It is seen that the power is decreased when the consumption at point B is increased. This indicates that the EV measures the total flow to and from the MAIN and not only the power delivered from the charger. In point C (red graph in Fig. 8), the power shows similar, but not opposite, trends as the power in point B. Given that this trend is not recursive, and does not show up on the input side (blue graph), the energy in these peaks must come from an energy bank in the AC/DC converter and is released when the load increases. The decline of power in the last 35 minutes is caused by the BMS trying to level the voltage of the individual cells in the MAIN.

The four graphs in Fig.9 shows the power efficiency at any second during the charge for two different methods at two different input power levels. The EV is charged with 2.3 kW and 3.7 kW and the efficiency is found with the methods presented earlier for  $\eta_1$  and  $\eta_2$ . It is clear that the peaks from the measurements in the previous figure (Fig.8) occur at both power levels.

The dashed lines represents the energy efficiency from table I. It is calculated the same way, but instead of finding the ratio between the static power at the two measuring points, it is the ratio of the accumulated energy as seen in the following section.

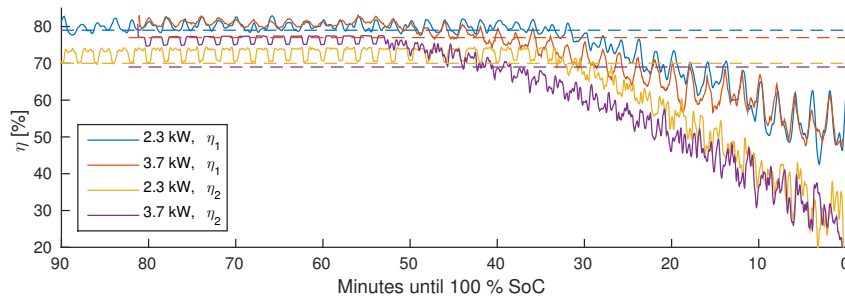

Figure 9: Power efficiency for Peugeot iOn during charging.

## 4.2 Nissan LEAF

Measuring point C is not available on the LEAF so the only available methods for finding the power efficiency is  $\eta_2$  and  $\eta_3$ . The initial raw data from the CAN-bus has large quantisation steps of 0.5 A for the measurements of the MAIN current. After applying a low pass filter, the data can now be seen in Fig.10.

During charging of Nissan LEAF, the consumption of energy in point B is constant, but of the same magnitude as on Peugeot iOn. Unlike Peugeot iOn, the BMS in the Nissan LEAF reduces the drawn current when the SOC reaches a much higher level. Comparing  $\eta_2$  for Nissan LEAF to  $\eta_2$  for Peugeot

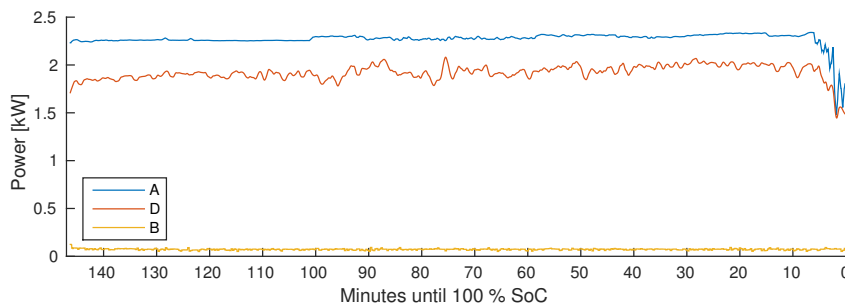

Figure 10: Power at various measuring points for Nissan LEAF during 2.3 kW charge.

iOn, the LEAF has a better efficiency. However, the large quantisation steps causes less precise measurements and results in spikes exceeding 100 % efficiency. Since the high voltage side is inaccessible for measurements it is unknown whether the internal measurements from the CAN-bus are made the same way. The graphs in Fig.11 shows the efficiency at any given second during charging. The dashed line represents the finite energy efficiency of table I.

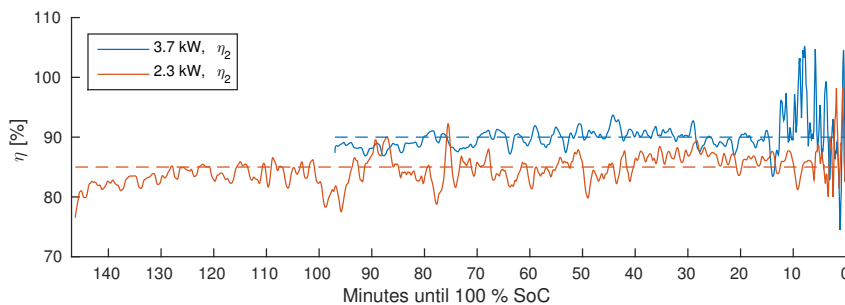

Figure 11: Power efficiency for Nissan Leaf during charge.



### 4.3 Energy efficiency

In section 4.1 and 4.2 the power efficiency has been calculated with equation 1 and 2 and visualised in graphs for every second. In order to compare method 1 and 2 to method 3, equation 1 and 2 must be rewritten to represent the energy efficiency, i.e. the efficiency for the entire charge with a single number. See equation 4 and 5.

$$\eta_{1,E} = \frac{1}{N} \sum_{n=1}^N \eta_1 \quad (4)$$

$$\eta_{2,E} = \frac{1}{N} \sum_{n=1}^N \eta_2 \quad (5)$$

Table 1 shows the energy efficiency for the different models of EVs tested with the described methods. All EVs have been tested when charging with the most used charging powers according to the 61851 IEC standard. Mode 2 2.3 kW single-phase for all three EVs and mode 2 3.7 kW single-phase for iOn and LEAF. Renault Zoe use the Mennekes plug, which makes it possible to charge with mode 3 and 4, three-phase 11 kW, 22 kW and 43 kW. On Peugeot iOn,  $\eta_3$  is 2 % lower than  $\eta_{1,E}$ , which can be explained by

Table 1: Efficiency of three tested EVs at different charge levels.

EV	Charge standard	Charge power	Energy Efficiency		
			$\eta_3$	$\eta_{2,E}$	$\eta_{1,E}$
iOn	10 A @ 1 phase	2.3 kW	77 %	70 %	79 %
iOn	16 A @ 1 phase	3.7 kW	75 %	69 %	77 %
LEAF	10 A @ 1 phase	2.3 kW	74 %	85 %	
LEAF	16 A @ 1 phase	3.7 kW	70 %	90 %	
Zoe	10 A @ 1 phase	2.3 kW	49 %		
Zoe	16 A @ 3 phase	11 kW	64 %		
Zoe	32 A @ 3 phase	22 kW	65 %		
Zoe	63 A @ 3 phase	43 kW	63 %		

heat dissipation in the MAIN and loss in the DC/DC converter.  $\eta_{2,E}$  is expected to be between  $\eta_{1,E}$  and  $\eta_3$  since the loss in the DC/DC converter is not included, however this result show a significant lower efficiency. This is due to the unknown measure points of the internal measuring network.

On the Nissan LEAF,  $\eta_3$  is, like the Peugeot iOn, lower for 3.7 kW than 2.3 kW.  $\eta_{2,E}$ , shows a significant decrease, but the CAN-bus data is linked with a high uncertainty.

On Renault Zoe the CAN-bus identifiers are unknown, so the internal voltage and current measurements of the MAIN can not be accessed. Like most EVs the high voltage side is completely isolated, which makes the only estimate of the chargers efficiency method 3.  $\eta_3$  is 10 % lower for the Zoe than  $\eta_3$  for the other EVs. When charging the Zoe with 10 A single-phase mode 2, the efficiency drops about 15 %. The charger is optimised to a range considerably larger than the other EVs as it can charge with up to 63 A three-phase. The OEM has prioritised fast AC charging and the ability to switch between single- and three-phase strategy at the cost of efficiency.

A 3-phased charger can use the system voltage of 400 V and use a buck converter to step it down to the MAIN voltage. When only one phase of the charger is used, the line voltage is 230 V and that causes a larger loss in the rectifier and means that a boost converter is needed to achieve the higher MAIN voltage. That explains the lower efficiency when charging the Zoe with 10 A single-phase.

### 4.4 Converter characteristics

Fig. 12 shows the efficiency vs. the charging current for Peugeot iOn. The graph is based on the measurements on both sides of the charger and shows the maximum, mean and minimum efficiency for every input current level. This demonstrates how AC/DC converters are optimised to a certain range of input power where they have maximum efficiency. The efficiency drops when the input leaves the optimised area. The peak efficiency is reduced to gain a better efficiency for a wider range of load conditions.

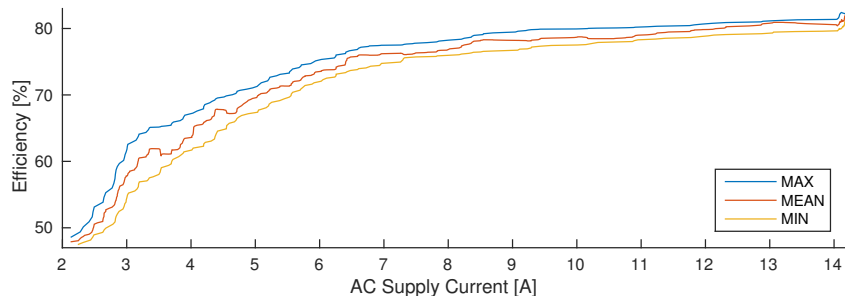

Figure 12: Power efficiency for different charging current on Peugeot iOn.

## 5 Conclusion

A unified test method ( $\eta_3$ ) for measuring the efficiency of the on-board EV charger has been presented. The method has been tested on three different EVs, and compared to two other methods.

The accessible wiring and practical connections are different for each EV, but the required measurement points were identified on all three EVs. The results show an efficiency between 49 % and 77 %. The large difference can be explained by the different design criteria of the converters. Two is designed for single-phase charging, and one for both single- and three-phase charging.

Other methods are logged CAN-bus data ( $\eta_2$ , two EVs) and direct access ( $\eta_1$ , one EV).  $\eta_1$  is the most precise method and is considered as a control measure.  $\eta_2$  appears to be the least precise measure of the efficiency because it is unknown how the EV calculates the different quantities. It is 8-9 % lower than the  $\eta_1$ .

$\eta_3$  is 2 % lower than  $\eta_1$  at two different levels of charge power. The 2 % difference could be explained by the consumption in the battery, the DC/DC converter and the standby consumption of the motor inverter. Since the charger is responsible for most of the power loss it is still a close estimate that can be used to compare different models.

## References

- [1] Baha M. Al-Alawi and Thomas H. Bradley, *Review of hybrid, plug-in hybrid, and electric vehicle market modelling studies*, Renewable and Sustainable Energy Reviews 21, p.190–203, 2013.
- [2] Kristien Clement-Nyns, Edwin Haesen and Johan Driesen, *The Impact of Charging Plug-In Hybrid Electric Vehicles on a Residential Distribution Grid*, IEEE Transactions on Power Systems, Vol. 25, No. 1, p. 371-380, 2010.
- [3] Katarina Knezović, Mattia Marinelli, René Juul Møller, Peter Bach Andersen, Chresten Træholt, Fabrizio Sossan, *Analysis of Voltage Support by Electric Vehicles and Photovoltaic in a Real Danish Low Voltage Network*, 49th International Universities' Power Engineering Conference, p. 1-6, 2014.
- [4] Willett Kempton and Jasna Tomic, *Vehicle to grid power implementation: From stabilizing the grid to supporting large scale renewable energy*, Journal of Power Sources, Vol. 144(1), p. 280-294, 2015.
- [5] K.Guépratte, P-O.Jeannin, D.Frey, H. Stephan, *High Efficiency Interleaved Power Electronics Converter for wide operating power range*, IEEE 24. annual Applied Power Electronics Conference and Exposition, p. 413-419, 2009.
- [6] Klaus Muehlbauer, Fabian Bachl, Dieter Gerling, *Analysis of Power Losses in AC/DC-Converter for Electric Vehicle Drive*, IEEE Vehicle Power and Propulsion Conference, p. 1-4, 2011.
- [7] Henry Oman and Sid Gross *Electric-Vehicle Batteries*: Ieee Aerospace and Electronic Systems Magazine — 1995, Volume 10, Issue 2, pp. 29-35
- [8] M. Svendsen, M. Winther-Jensen, A. Bro Pedersen, P. Bach Andersen, T. Meier Sørensen, *Electric Vehicle Data Acquisition System*, IEEE International Electric Vehicle Conference, p. 1-6, 2014.
- [9] Farhan Beg, *A Novel Design Methodology for a 1.5 KW DC/DC Converter in EV and Hybrid EV Applications*, WASET International Journal of Electrical, Computer, Electronics and Communication Engineering, Vol. 8, No. 9, 2014.

- [10] Søren Højgaard Jensen, Claus Nygaard Rasmussen, Guangya Yang, *WP 1.5 BATTERY MODELING*, Edison Report Rep1.5, 2012.