

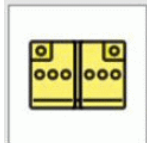



Rescue Sheet standard translation (Italian)







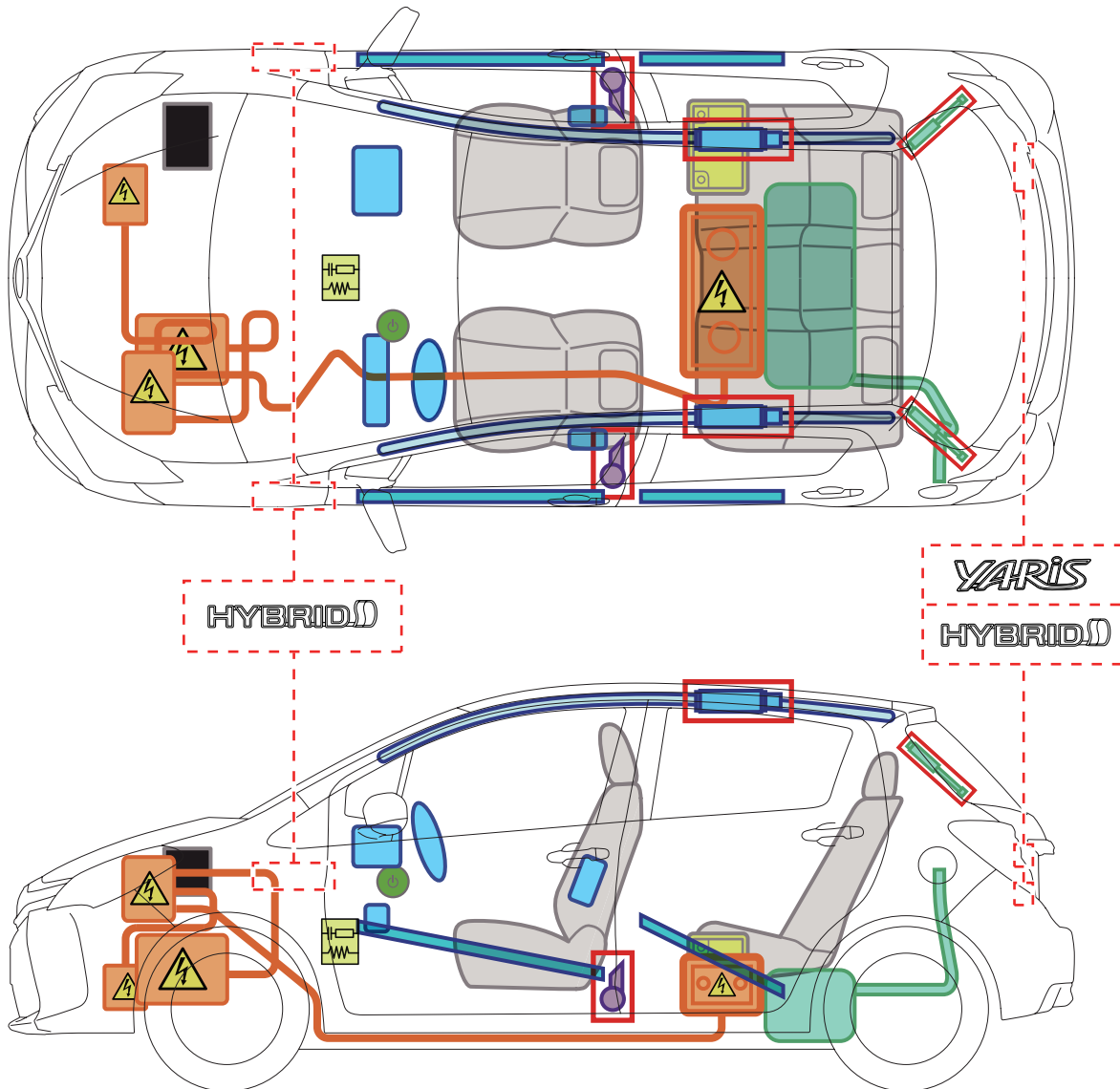





 <p>Airbag</p>	 <p>Rinforzi strutturali della carrozzeria</p>	 <p>Centralina di controllo</p>	 <p>Generatore di gas</p>
 <p>Molle a gas</p>	 <p>Batteria</p>	 <p>Protezione attiva anti-ribaltamento</p>	 <p>Tenditore della cintura di sicurezza</p>
 <p>Pretensionatore della cintura di sicurezza</p>	 <p>Serbatoio carburante</p>	 <p>Serbatoio (GPL o Metano)</p>	 <p>Valvola di sicurezza (GPL o Metano)</p>
 <p>Componenti ad alta tensione</p>	 <p>Componenti o cavi ad alta tensione</p>	 <p>Punto di disconnessione della batteria ad alta tensione</p>	 <p>Batteria ad alta tensione</p>
 <p>Sensore meccanico</p>			

Toyota Yaris Hybrid

(XP13 M (a) 5-Türer, ab 07/2014)



Legende

	Zündschalter		Karosserie- verstärkung		Steuergerät
	Airbag		Gasdruck- dämpfer		12 Volt- Batterie
	Gas- generator		Kraftstoff- tank		Hochvolt- bauteile
	Gurtstraffer		Sicherungs- kasten		Hochvolt- Batterie

A

Toyota Yaris Hybrid (XP13 M (a) 5-Türer, ab 07/2014)

Toyota Yaris Hybrid

(XP13 M (a) 5-Türer, ab 07/2014)



12V Spannungsversorgung trennen

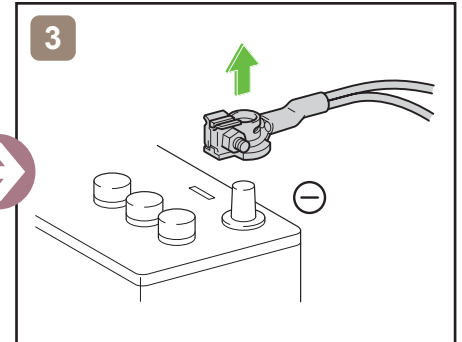
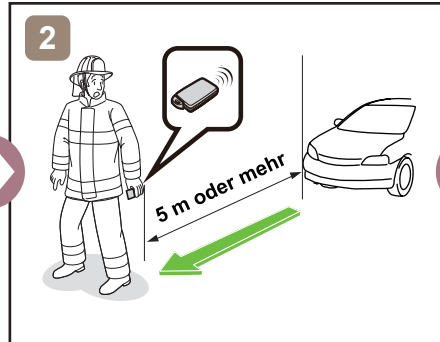
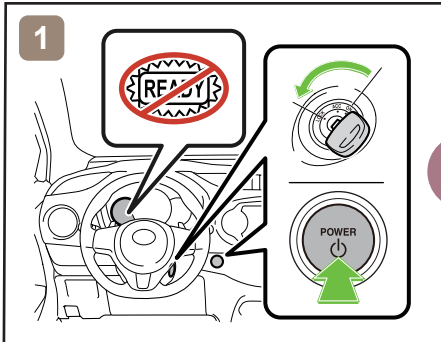

oder

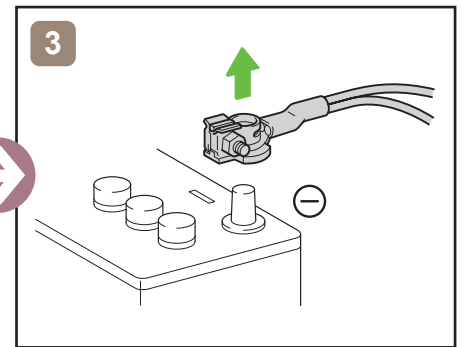
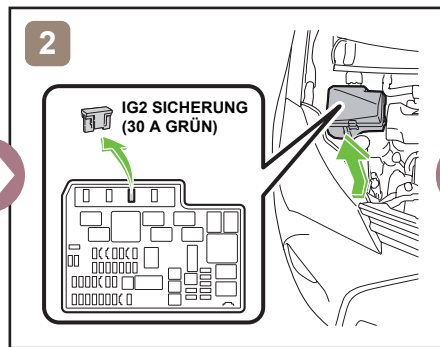
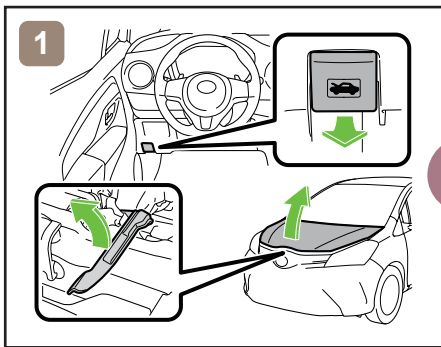

Zugang 12V Batterie

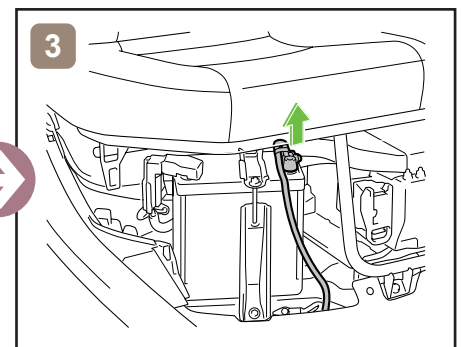
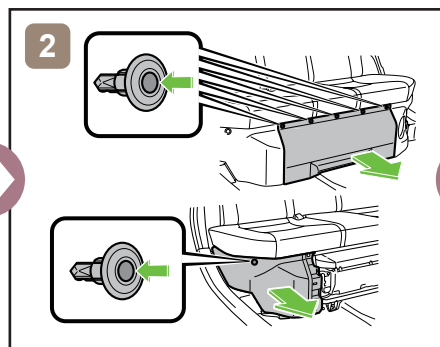
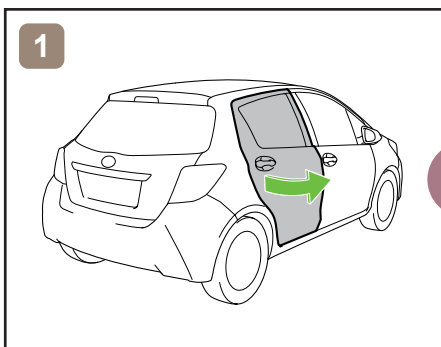

Hinweise zum Transport

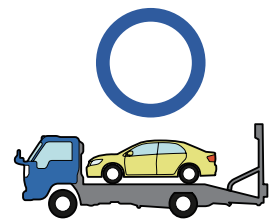
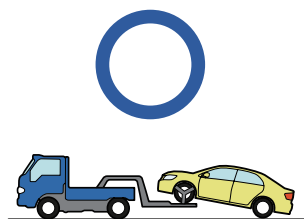
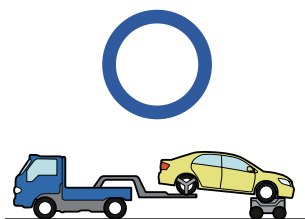
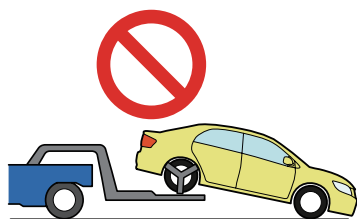

Erkennungsmerkmale:

- Schriftzug „HYBRID“ auf der Heckklappe.
- „HYBRID“-Schriftzug an den Kotflügeln vorn.
- Schriftzug am Motor.
- Silber-blaues Markenemblem Front und Heck.



	<p>Anmerkungen: Bei Unfällen mit ausgelöstem Airbag ist die Hochvoltanlage spannungsfrei.</p> <ul style="list-style-type: none">• Zündung ausschalten.• 12-Volt-Batterie: Minus-Pol trennen. <p>Bei Unfällen mit nicht ausgelöstem Airbag.</p> <ul style="list-style-type: none">• Zündung ausschalten.• 12-Volt-Batterie: Minus-Pol trennen.
--	--

	<p>Lebensgefahr! Hochvoltbauteile nicht berühren!</p>
--	--

Die Hochvoltbatterie befindet sich unter der Rücksitzbank.
Kennzeichnung der Hochvoltbatterie:

! DANGER       	
HOCHSPANNUNG / ALKALISCHES ELEKTROLYT	
Um Verletzungen, Verbrennungen oder Elektroschock zu vermeiden:	
<ul style="list-style-type: none">• Zerlegen Sie niemals diese Batterie und entfernen Sie auch nicht die Gehäusedecke! - Service nur von qualifizierten Technikern -• Vermeiden Sie den Kontakt von alkalischem Elektrolyt mit Augen, Haut oder Kleidung. Sollten Sie doch damit in Berührung kommen, spülen Sie mit Wasser und begeben Sie sich unverzüglich in ärztliche Hilfe.• Halten Sie Kinder von dieser Batterie fern.• Beschädigen Sie die Batterie nicht beim Transport mit Gabelstaplern. Hantieren Sie auch nicht mit offener Flamme und verbrennen Sie die Batterie nicht. Sollte Elektrolyt austreten, kann Hitze erzeugt werden, welche zum Brand führen kann.	
Für die qualifizierten Techniker:	
Gehen Sie gemäß dem Reparaturhandbuch vor, wenn Sie die Batterie warten oder erneuern.	
Recycling-Information für HV-Batterien:	
<ul style="list-style-type: none">• Transportieren Sie die Batterie stets gemäß den entsprechenden Gesetzen.• Für das Ersetzen und Entsorgen der Batterie wenden Sie sich bitte an Ihren nächsten TOYOTA-Prius-Händler.	