

Ensto Pro EVF100 / EVF200 / EVF300



Installation instructions
Operation instructions



Contents

1. EVF100 / EVF200 / EVF300.....	3
2. Safety Instructions.....	3
3. Delivery Contains.....	4
4. Accessories.....	6
5. Mounting instructions.....	11
5.1 Before Installation.....	11
5.2 EVF100 / EVF200 mounting on concrete casting at site.....	12
5.3 EVF100 / EVF200 mounting on ground mounting frame.....	14
5.4 EVF100 / EVF200 mounting on concrete foundation.....	16
5.5 EVF100 / EVF200 mounting on Unimi concrete foundation.....	18
5.6 EVF100 / EVF200 wall mounting.....	20
5.7 EVF300 mounting on concrete casting at site.....	22
5.8 EVF300 mounting on concrete foundation.....	25
6. Supply Connections.....	27
7. Commissioning.....	29
7.1 Connecting charging station to external communication.....	29
8. User Instructions.....	30
8.1 User Interfaces.....	30
8.2 Charging.....	30
9. Technical Data.....	31
10. Dimension Drawings.....	33
11. Installation / Commissioning Checklist.....	36
12. Maintenance / Preventive Maintenance Instructions.....	37
13. EVF100 Internal Wiring Diagram Example.....	38
14. Troubleshooting.....	40
15. Warranty.....	40

Ensto Pro

1. EVF100 / EVF200 / EVF300

Ensto Pro (EVF) is a solution for charging one or two electric vehicles. It is engineered especially for fast AC charging, but the station can be equipped also with domestic sockets.

EVF100: Single charging station

EVF200: Dual charging station

EVF300: Dual charging station and a distribution cabinet

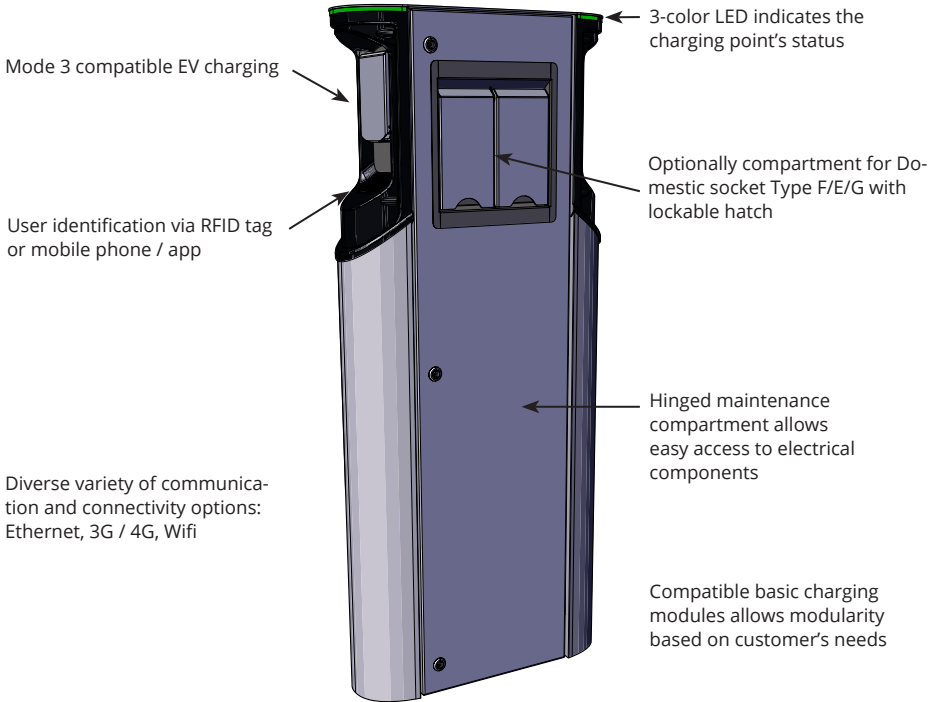

2. Safety Instructions

- *The charging station must be installed by a qualified person.*
- *Read the instruction manual before installation and usage of the charging station.*
- *The instruction manual must be stored in a safe location and be available for future installation and service.*
- *Follow the guidelines in the instruction manual when installing and using the charging station.*
- *The installation must be done according to the local safety regulations, restrictions, dimensioning, codes and standards.*
- *The information provided in this manual in no way exempts the user of responsibility to follow all applicable codes and safety standards.*





3. Delivery Contains

- EVF charging station
- Installation and Operation instructions

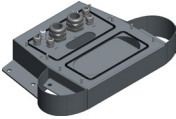
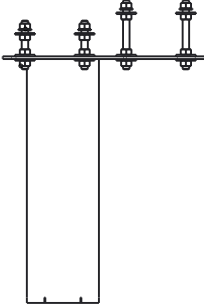
Note! The delivery does not include any installation accessories.
Please order needed accessories based on mounting method.

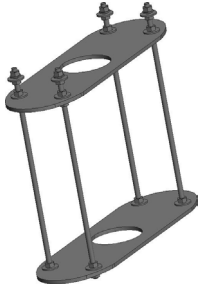
EVF300	
Installation method and site	Accessories
Ground mounting on concrete at site	Anchor bolts from a local supplier
Ground mounting on concrete foundation	<div style="display: flex; align-items: center;"> <div style="flex: 1;">  <p>EVTL35.00: Ground mounting box</p> </div> <div style="flex: 1;">  <p>EVTL37.00: Adapter</p> </div> <div style="flex: 1; padding-left: 20px;"> <p>Concrete foundation, product code SJR-08 from Sähkö-Jokinen Oy, https://www.sahkojokinen.fi/en</p> </div> </div>

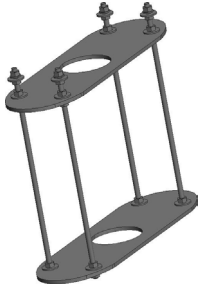
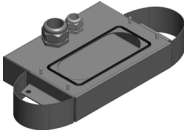
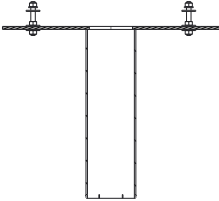
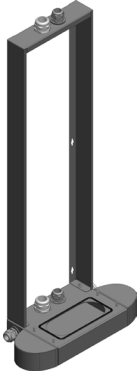
EVF100 / EVF200	
Installation method and site	Accessories
Ground mounting on concrete at site	 <p>Anchor bolts from a local supplier</p>
Ground mounting on ground mounting frame	
Ground mounting on concrete foundation	 <p>EVTL32.00: Ground mounting box, cable entry from bottom</p> <p>or</p>  <p>EVTL28.00: Ground mounting frame</p>
Ground mounting on Unimi concrete foundation	 <p>EVTL34.00: Ground mounting box, cable entry from top</p>  <p>EVTL36.00: Adapter</p> <p>Concrete foundation, product code SJR-08 from Sähkö-Jokinen Oy, https://www.sahkojokinen.fi/en</p>
Wall mounting	 <p>EVTL31.00: Wall installation kit including installation box and rail</p> <p>From Unimi Solutions: Concrete foundation, product code 100-1 Cover plate Adapter, product code 100-13 www.unimi.se</p>

4. Accessories

Order numbers and dimensions.

Ground mounting box for EVF100 / EVF200

EVTL32.00

EVTL32.00 is a ground mounting box with cable entry from bottom.

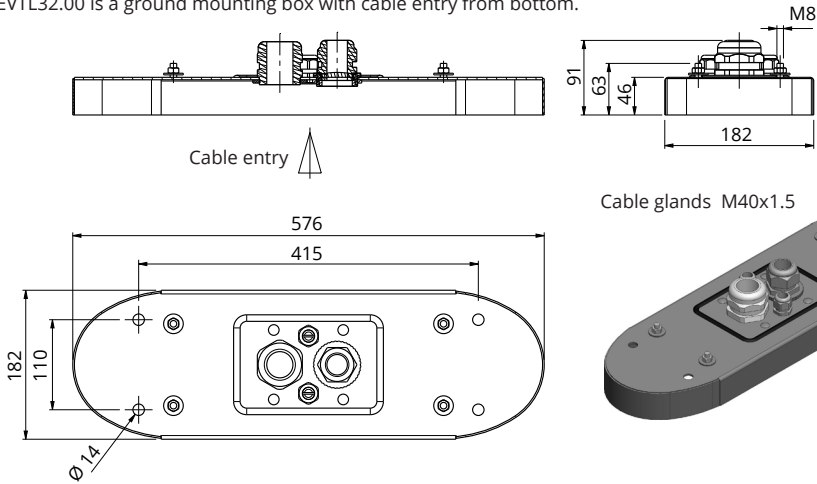

Ground mounting box for EVF100 / EVF200

EVTL34.00

EVTL34.00 is a ground mounting box with cable entry from top.

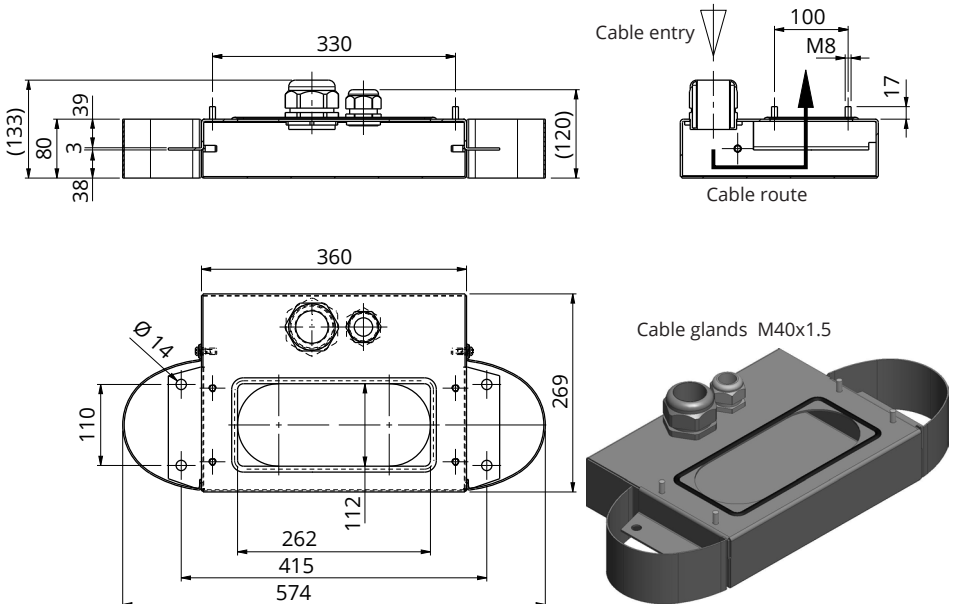

Ground mounting frame for EVF100 / EVF200

EVTL28.00

EVTL28.00 is a whole set as shown on the picture.

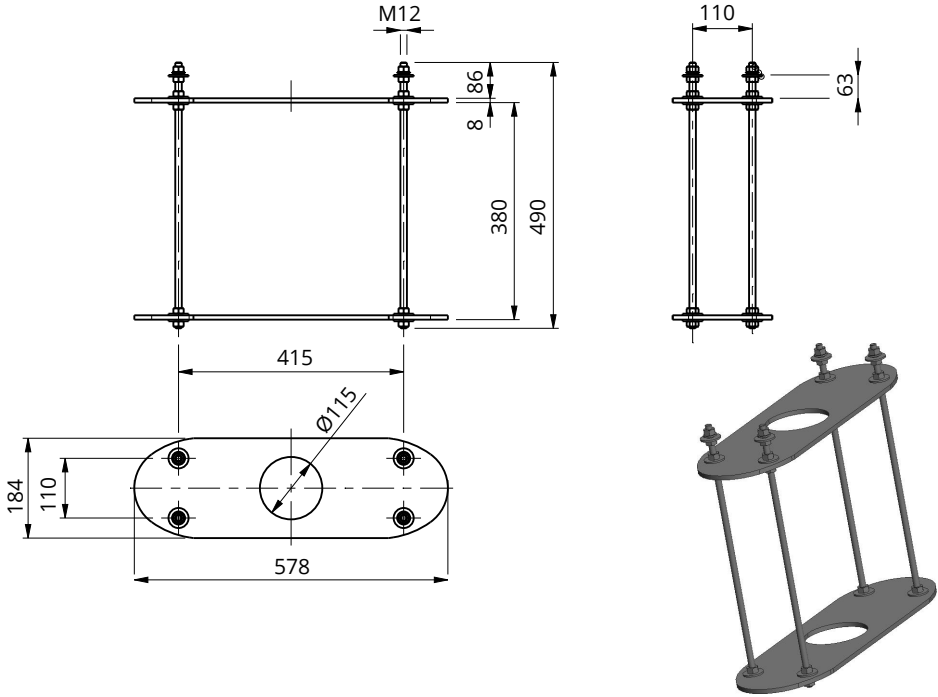

Concrete foundation adapter for EVF100 / EVF200

EVTL36.00

The concrete foundation adapter is designed to be used with a concrete foundation, product code SJR-08, supplied by Sähkö-Jokinen Oy. Please order the foundation from: <https://www.sahkojokinen.fi/en>

If you want to use a foundation from another manufacturer, make sure that the foundation is compatible with the adapter.

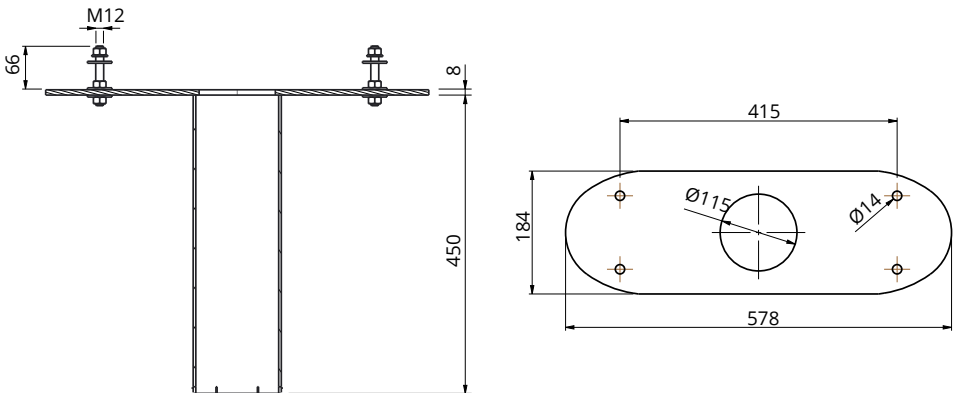

Wall Installation kit for EVF100 / EVF200

EVTL31.00

EVTL31.00 is a wall installation kit including installation box and rail.

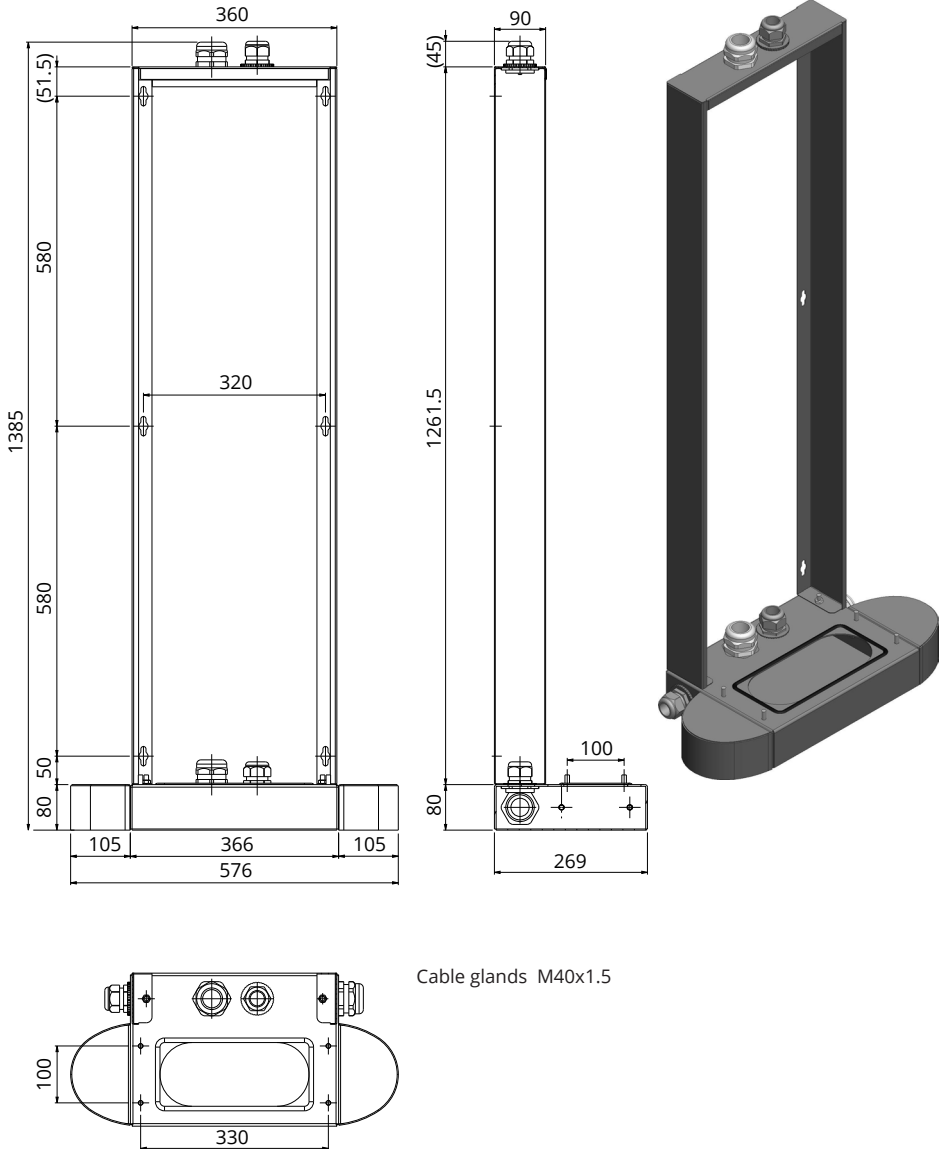

Mounting box for EVF300

EVTL35.00

EVTL35.00 is a ground mounting box with cable entry from bottom to the main board.

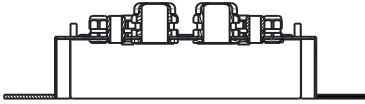
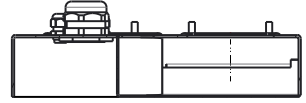
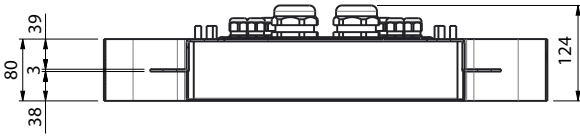

Cable glands M40x1.5

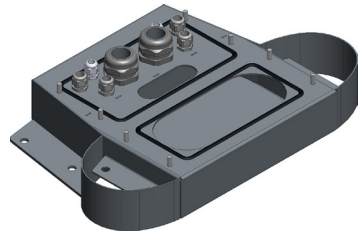
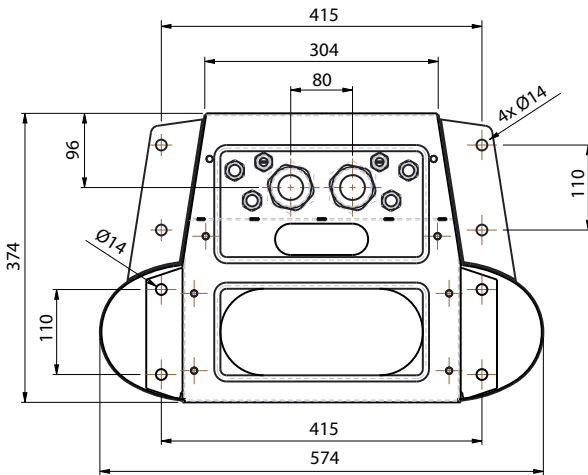

Concrete foundation adapter for EVF300

EVTL37.00

The concrete foundation adapter is designed to be used with Sähkö-Jokinen SJR-08 foundation. Please order the foundation from: <https://www.sahkojokinen.fi/en>

If you want to use a foundation from another manufacturer, make sure that the foundation is compatible with the adapter.

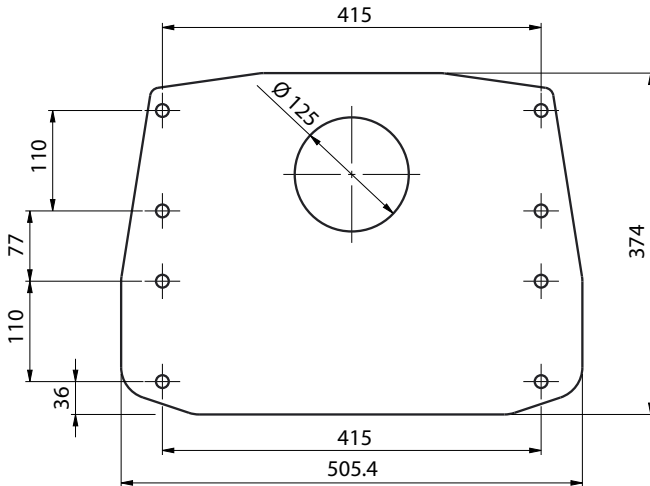
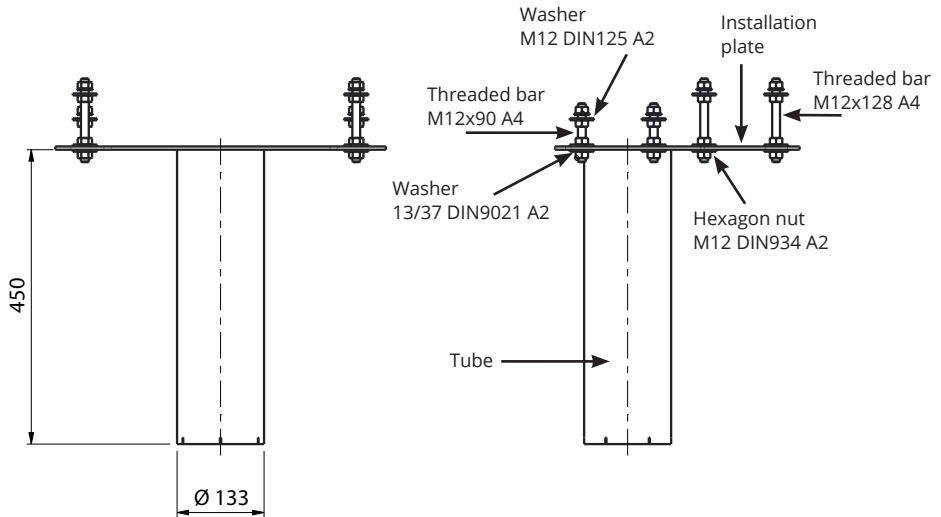

5. Mounting instructions

5.1 Before Installation

Remove the package around the charging station. Remove the film protecting the metal parts only after the installation is finished.

Note! When selecting the installation location, take into consideration the minimum space needed for operating and maintenance.

EVF100 / EVF200

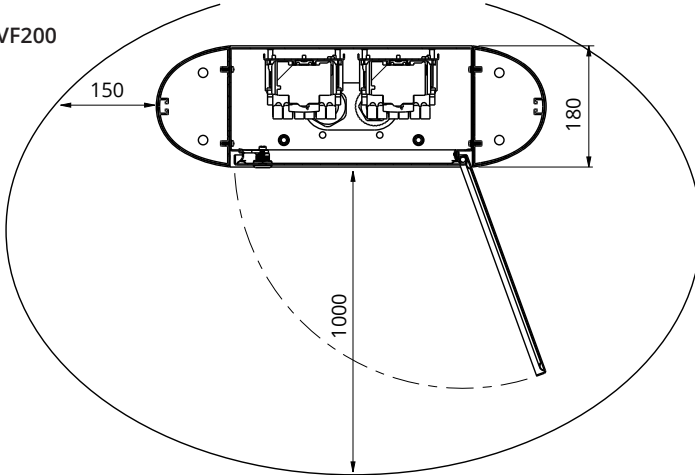

EVF300

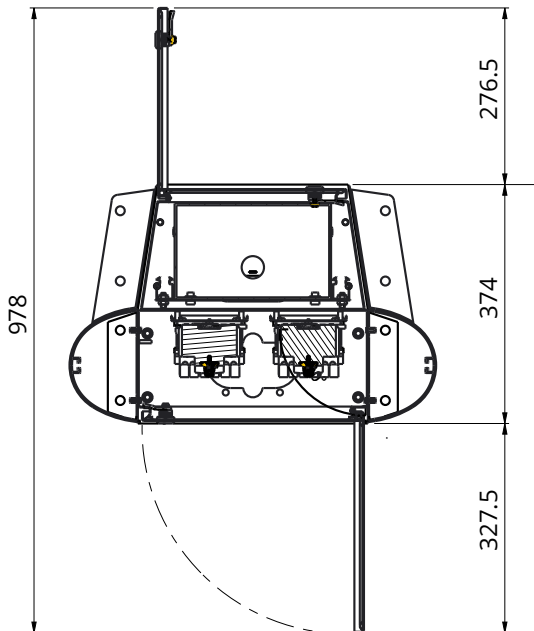

5.2 EVF100 / EVF200 mounting on concrete casting at site

Items needed:	Ground mounting box EVTL32.00 / EVTL34.00	1 pcs
	Anchor bolts M12	4 pcs
	Washers	
	Nuts	

Make sure that the materials used for the concrete foundation and the installation procedures follow local building regulations and safety standards.

- Dig a pit for the concrete foundation. The pit floor should be trampled and horizontal.
- Put cable and possible drain pipes in place.
- Fill the pit with concrete.
- Let the concrete solidify, make sure the surface stays solid and level during the process.

Installation steps

1. Drill a hole in the concrete for the anchor bolts. For more information see the anchor bolt instructions. Use the ground mounting box as a jig.

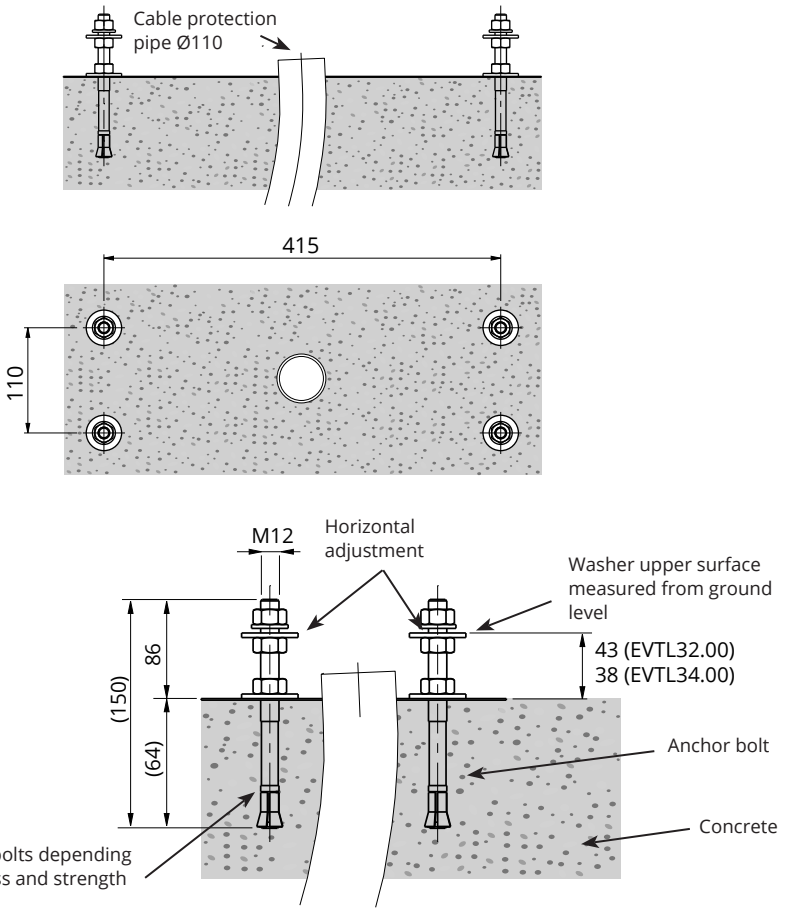

2. Put the anchor bolts in place and tighten the anchor bolt nuts.
3. Adjust nuts and washers on the anchor bolts horizontally.
4. Attach the mounting box to the anchor bolts using suitable washers and nuts.

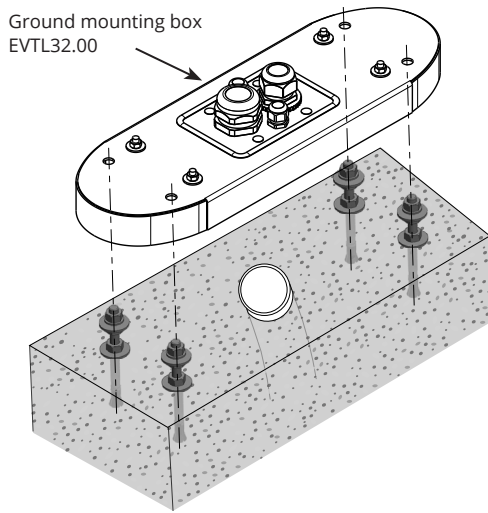

5. **EVTL32.00:** Pull electrical cables through the ground mounting box cable gland(s) approx. 400 mm measured from the upper surface of the mounting box.
6. **EVTL34.00:** Pull electrical cables through the ground mounting box cable gland(s) and further through the mounting box cable hole approx. 400 mm measured from the upper surface of the mounting box.
6. Tighten the cable gland(s). Close the unused cable entries with cable gland plugs.
7. Open the maintenance door.
8. Remove the nuts and washers from the ground mounting box.
9. Lift the EVF on the ground mounting box and pull the electrical cables through the cable hole.
10. Bolt the EVF in place using washers and nuts you removed from the ground mounting box.
11. **EVTL32.00:** Remove the supply cable sheath at the length of max. 200 mm.
12. **EVTL34.00:** Remove the supply cable sheath beginning from the cable gland exit.
13. Cut the supply cable conductors to different lengths. Cut the ground conductor longest, so that if a fault occurs it is the last one that comes loose.
14. Strip the supply cable conductors 25 mm.
15. Connect the supply cable wires to the supply terminal blocks.
16. Ensure that the PE is connected to the EVF.
17. Switch on F0, F1, F2 (if present) and QF1.
18. Close the maintenance door.

5.3 EVF100 / EVF200 mounting on ground mounting frame

Items needed:	Ground mounting frame EVTL28.00	1 pcs
	Ground mounting box EVTL32.00 / EVTL34.00	1 pcs

Make sure that the materials used for the concrete foundation and the installation procedures follow local building regulations and safety standards.

- Plan the installation depth so that the top surface of the ground mounting frame is not below the ground surface. Note! Consider the possible paving materials when setting the level.
- Dig a ca 490 mm deep pit in the ground. The pit floor should be trampled and horizontal.
- Place the ground mounting frame in the pit.
- Put cable and possible drain pipes in place.
- Pour concrete over the frame and pipes.
- Let the concrete solidify, make sure the surface stays solid and level during the process.

Installation steps

1. Remove the upper nuts and washers on the top of the ground mounting frame bolts.
2. Place the mounting box on the mounting frame.
3. Adjust the nuts on the mounting frame bolts so that the top surface of the mounting box is horizontal.
4. **EVTL32.00:** Pull electrical cables through the ground mounting box cable gland(s) approx. 400 mm measured from the upper end of the mounting box.
EVTL34.00: Pull electrical cables through the ground mounting box cable gland(s) and further through the mounting box cable hole approx. 400 mm measured from the upper end of the mounting box.
5. Tighten the cable gland. Close the unused cable entries with cable gland plugs.
6. Open the maintenance door.
7. Remove the nuts and washers from the ground mounting box.
8. Lift the EVF on the mounting box and pull the electrical cables through the cable hole.
9. Bolt the EVF in place using the washers and nuts you removed from the ground mounting box.
10. **EVTL32.00:** Remove the supply cable sheath at the length of max. 200 mm.
EVTL34.00: Remove the supply cable sheath beginning from the cable gland exit.
11. Cut the supply cable conductors to different lengths. Cut the ground conductor longest, so that if a fault occurs it is the last one that comes loose.
12. Strip the supply cable conductors 25 mm.
13. Connect the supply cable wires to the supply terminal blocks.
14. Ensure that the PE is connected to the EVF.
15. Switch on F0, F1, F2 (if present) and QF1.
16. Close the maintenance door.

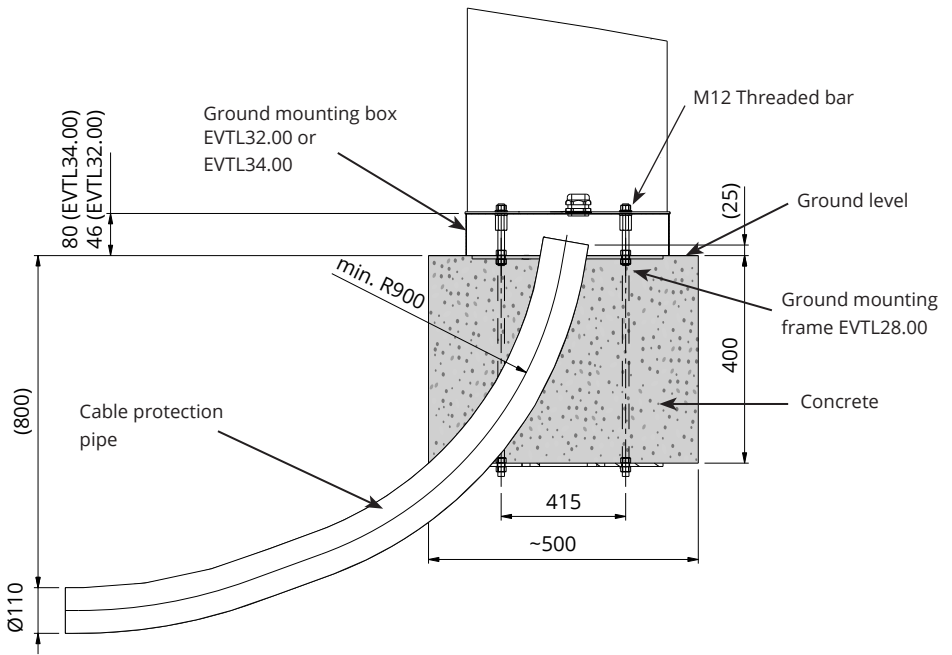

5.4 EVF100 / EVF200 mounting on concrete foundation

Items needed:	Ground mounting box EVTL32.00 / EVTL34.00	1 pcs
	Adapter for concrete foundation EVTL36.00	1 pcs
	Concrete foundation	1 pcs

This example describes installation procedure using concrete foundation, product code SJR-08, supplied by Sähkö-Jokinen Oy.

If you want to use a foundation manufactured by another supplier, make sure that the foundation is compatible with the adapter.

- Plan the installation depth so that the top surface of the adapter is not below the ground surface. Note! Consider the possible paving materials when setting the level.
- Dig a pit for cable conduits and the concrete foundation. The pit floor should be trampled and horizontal.
- Lift the foundation in the pit.
- Put cable and possible drain pipes in place. Install the pipes in relevant inlets.
- Cover the unused inlets with plugs.
- Tighten the foundation to its place by filling the excess space outside the foundation with gravel.

Installation steps

1. Assemble the concrete foundation adapter.
2. Attach the mounting box EVTL32.00 / EVTL34.00 on the concrete foundation adapter EVTL36.00 and place the assembly on the concrete foundation.
3. Tighten the assembly in place using the screws on the concrete foundation.
4. **EVTL32.00:** Pull electrical cables through the ground mounting box cable gland(s) approx. 400 mm measured from the upper end of the mounting box.
EVTL34.00: Pull electrical cables through the ground mounting box cable gland(s) and further through the mounting box cable hole approx. 400 mm measured from the upper end of the mounting box.
5. Tighten the cable gland. Close the unused cable entries with cable gland plugs.
6. Open the maintenance door.
7. Remove the nuts and washers from the ground mounting box.
8. Lift the EVF on the mounting box and pull electrical cables through the cable hole.
9. Bolt the EVF in place using the washers and nuts you removed from the ground mounting box.
10. **EVTL32.00:** Remove the supply cable sheath at the length of max. 200 mm.
EVTL34.00: Remove the supply cable sheath beginning from the cable gland exit
11. Cut the supply cable conductors to different lengths. Cut the ground conductor longest, so that if a fault occurs it is the last one that comes loose.
12. Strip the supply cable conductors 25 mm.
13. Connect the supply cable wires to the supply terminal blocks.
14. Ensure that the PE is connected to the EVF.
15. Switch on F0, F1, F2 (if present) and QF1.
16. Close the maintenance door.

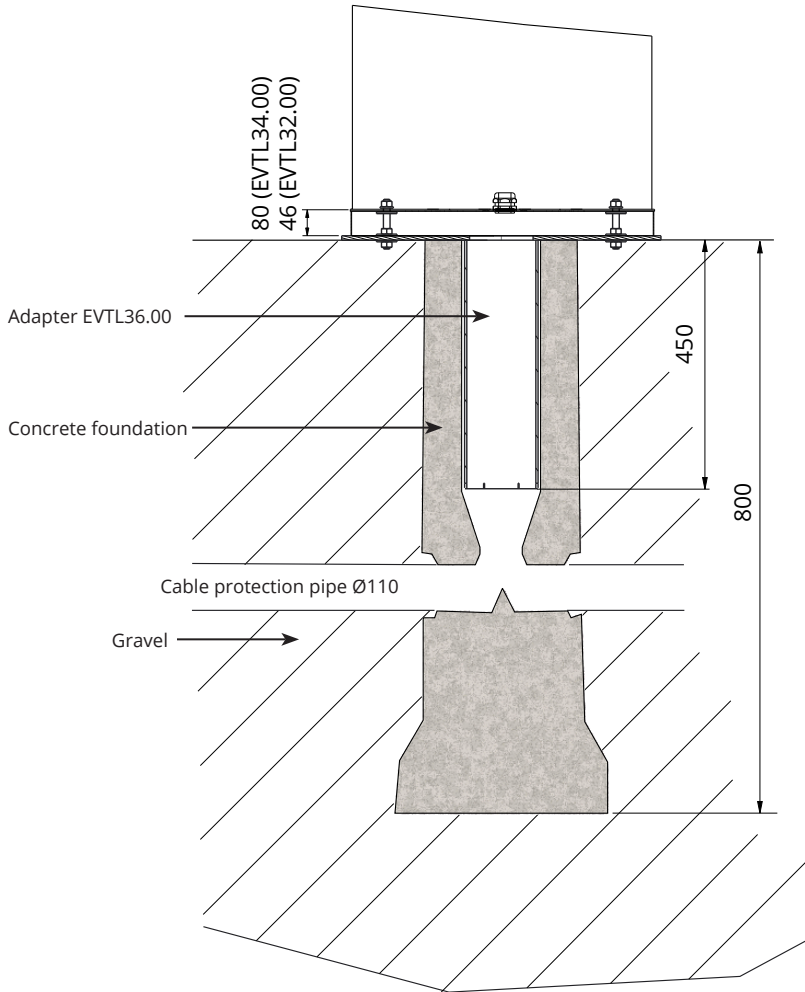

5.5 EVF100 / EVF200 mounting on Unimi concrete foundation

This example describes installation procedure using a concrete foundation supplied by Unimi Solutions.

Items needed:	Ground mounting box EVTL32.00 / EVTL34.00	1 pcs
	Please order the following items from www.unimi.se	
	Concrete foundation Ensto Pro, product code 100-1	1 pcs
	Cover plate	1 pcs
	Ensto EVF compatible adapter element, product code 100-13	1 pcs

Installation steps

Figure 1

- Prepare trenching for cable conduits and the concrete foundation to necessary depths.
- Add gravel to the bottom of the trench, to such thickness that the top of the foundation will reach desired level when lifted into the hole. Note! Consider the possible paving materials when setting the level.
- Cover the unused conduit openings with plugs accompanying the foundation.
- Lift the foundation into the installation pit, the attachment bar embedded in the foundation can be used as a lifting point. The attachment bar should be oriented to allow attachment of the EVF into desired position.
- Lay the cable conduits into the trenches and install conduits to relevant inlets.
- Pull electric cables through the conduits into the foundation.



Figure 2

- Tighten the foundation to its place by filling the excess space outside the foundation with gravel.
- Set the final layer of gravel so that the top of the foundation will be flush with ground or the final paving material.
- Always place a cover plate on the foundation if the EVF charging station is installed in a separate session than the foundation.



Figure 3

- When starting the installation of the EVF charging station remove the cover plate.



Figure 4

- Place the adapter element on the foundation and tighten the captive screws, 3 pcs.
- Remove the upper nuts and upper pair of washers from the adapter element. (Ensure there is one polyamide washer on each side of the mounting box.)
- Pull the supply cable and possible data cable through the hole in the center of adapter.



Figure 5

- Place the mounting box on the adapter element.
- Bolt the mounting box in place using the washers and nuts you removed from the adapter element. (Ensure there is one polyamide washer on each side of the mounting box.)
- Hint: to make it easier to certain that the mounting box is levelled, first flip it upside down and position the nuts under it so that it becomes levelled and then flip it over again and tighten the upper nuts and washers.
- **EVTL32.00:** Pull electrical cables through the ground mounting box cable gland(s) approx. 400 mm measured from the upper end of the mounting box.
- **EVTL34.00:** Pull electrical cables through the ground mounting box cable gland(s) and further through the mounting box cable hole approx. 400 mm measured from the upper end of the mounting box.
- Tighten the cable gland. Close the unused cable entries with cable gland plugs.

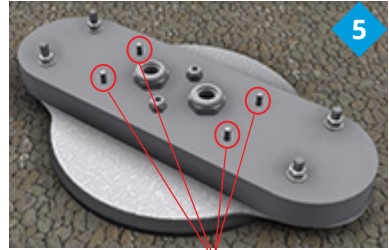

Bolt the EVF in place

Figure 6

- Open the maintenance door.
- Remove the nuts and washers from the ground mounting box.
- Lift the EVF on the mounting box and pull the electrical cables through the cable hole(s).
- Bolt the EVF in place using the washers and nuts you removed from the ground mounting box.
- **EVTL32.00:** Remove the supply cable sheath at the length of max. 200 mm.
- **EVTL34.00:** Remove the supply cable sheath beginning from the cable gland exit.
- Cut the supply cable conductors to different lengths. Cut the ground conductor longest, so that if a fault occurs it is the last one that comes loose.
- Strip the supply cable conductors 25 mm.
- Connect the supply cable wires to the supply terminal blocks.
- Ensure that the PE is connected to the EVF.
- Switch on F0, F1, F2 (if present) and QF1.
- Close the maintenance door.

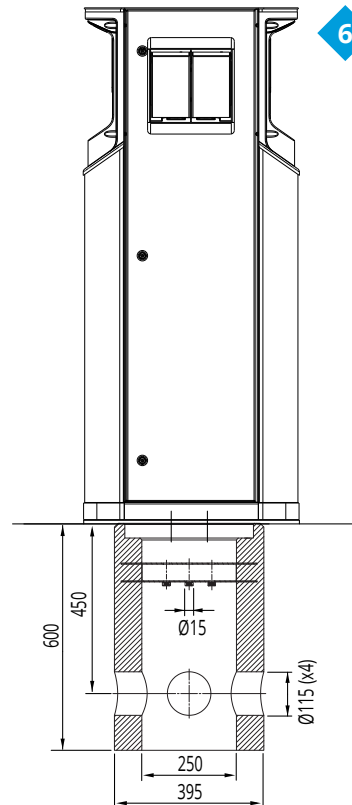

5.6 EVF100 / EVF200 wall mounting

Items needed:	Wall mounting kit EVTL31.00	1 pcs
	Screws or bolts	
	Washers	
	Nuts	

Installation steps

1. Ensure that the wall is robust and stable. The mounting surface must be flat and vertical.
2. Prepare the wall for installation and select the screw / bolt type depending on the wall type. Exercise extreme caution when drilling holes in the wall.
3. Install the wall mounting kit EVTL31.00 on the wall using 6 pcs of suitable screws / bolts, washers and nuts.
4. Adjust the installation rail so that the mounting box is perpendicular to the ground.
5. Pull electrical cables through the cable gland(s) on wall mounting bracket roof approx. 2 m.
6. Alternative cable entry is from mounting box sides.
7. Pull the electrical cables through the cable gland(s) on the mounting box.
8. Tighten the cable glands. Close the unused cable entries with cable gland plugs.
9. Open the maintenance door.
10. Remove the nuts and washers from the ground mounting box.
11. Lift the EVF on the mounting box and pull the supply cable conductors through the cable hole.
12. Bolt the EVF in place using the washers and nuts you removed from the ground mounting box.
13. Attach the top part of the EVF to the wall mounting bracket with adhesive tape (included in the delivery).
14. Drill 2 pcs holes through the EVF enclosure and top bar of the wall mounting bracket; 74,5 mm measured from inside the enclosure. Make sure not to damage any components or internal wiring when drilling the holes.
15. Secure the EVF to the wall bracket with screws and sealing washers (included in the delivery). Place the sealing washer between the screw and the enclosure.
16. Remove the supply cable sheath, beginning from the cable gland exit.
17. Cut the supply cable conductors to different lengths. Cut the ground conductor longest, so that if a fault occurs it is the last one that comes loose.
18. Strip the supply cable conductors 25 mm.
19. Connect the supply cable wires to the supply terminal blocks.
20. Ensure that the PE is connected to the EVF.
21. Switch on F0, F1, F2 (if present) and QF1.
22. Close the maintenance door.

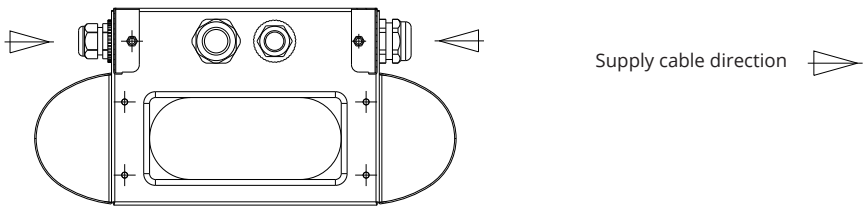
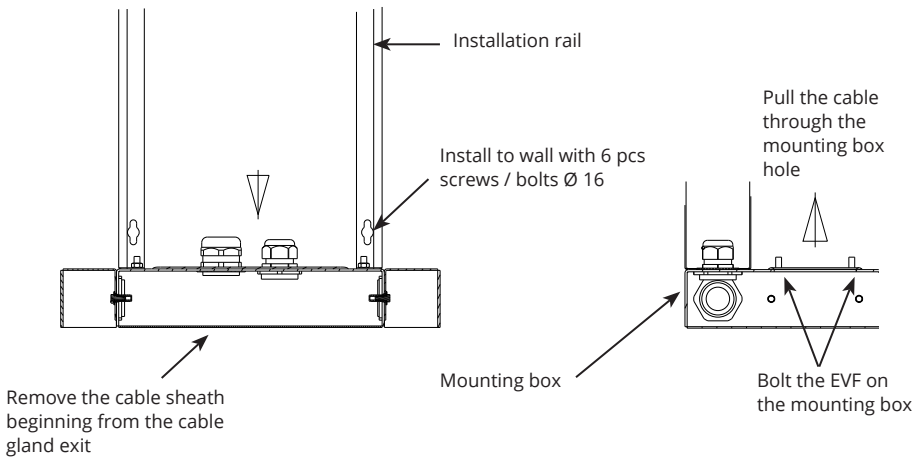
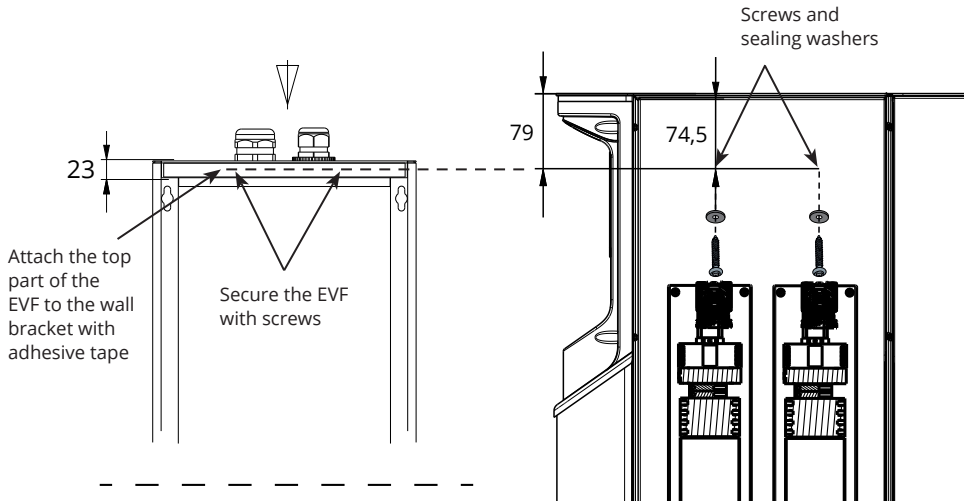

5.7 EVF300 mounting on concrete casting at site

Items needed:	Ground mounting box EVTL35.00	1 pcs
	Anchor bolts M12	8 pcs
	Washers	
	Nuts	

Make sure that the materials used for the concrete foundation and the installation procedures follow local building regulations and safety standards.

- Dig a pit for the concrete foundation. The pit floor should be trampled and horizontal.
- Install the cable pipes (supply and output chaining) and, if necessary, the cable pipe for the data cable into the ground.
- Fill the pit with concrete.
- Let the concrete solidify, make sure the surface stays solid and level during the process.

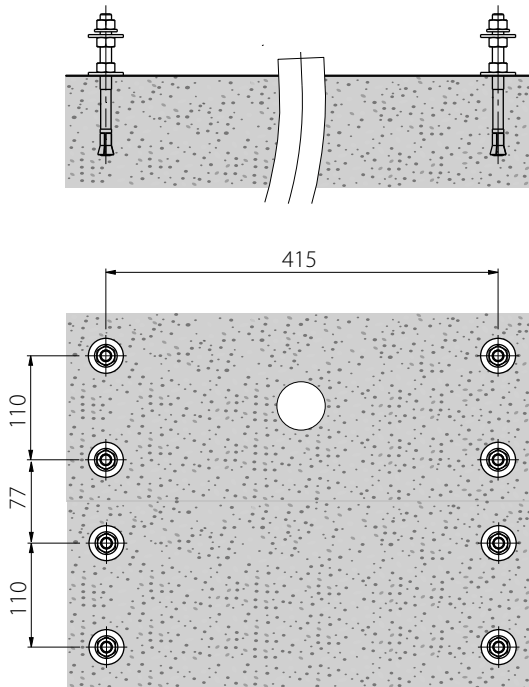

Installation Steps

1. Drill a hole in the concrete for the anchor bolts. For more information see the anchor bolt instructions. Use the ground mounting box as a jig.
2. Put the anchor bolts in place and tighten the anchor bolt nuts.
3. Adjust nuts and washers on the anchor bolts horizontally.
4. Place the ground mounting box on the concrete.

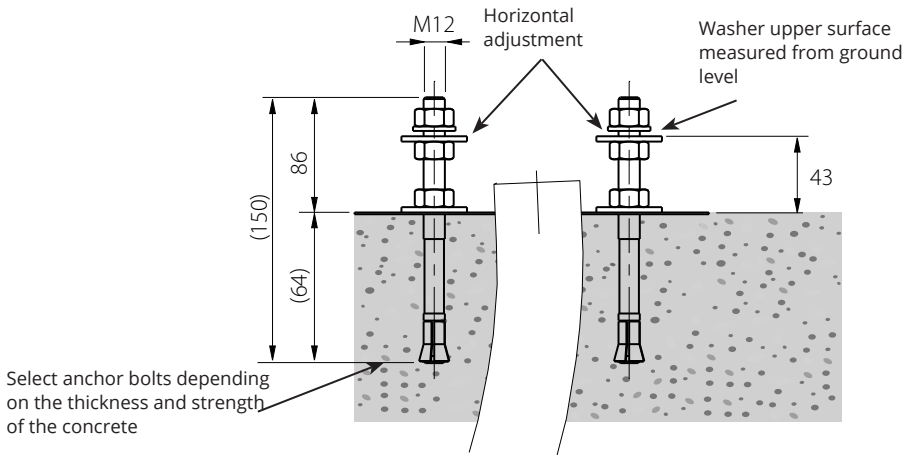

5. Attach the mounting box to the anchor bolts using suitable washers and nuts.
6. Pull electrical cables through the ground mounting box cable gland(s) approx. 450 mm measured from the upper surface of the mounting box.
7. Tighten the cable gland. Close the unused cable entries with cable gland plugs.

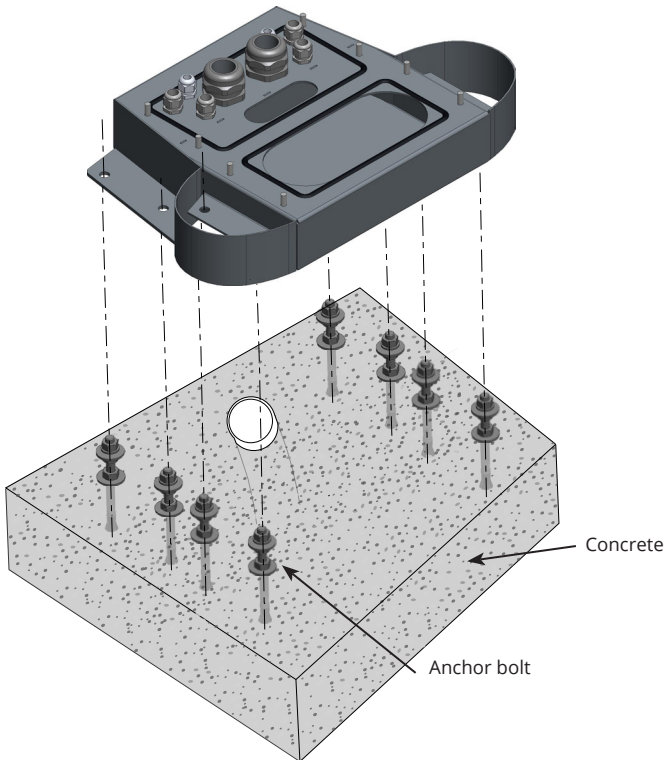

8. Remove the nuts and washers from the ground mounting box.
9. Open the distribution cabinet's maintenance door.
10. Lift the distribution cabinet module on the mounting box and bolt it in place, max. tightening torque 14 Nm.
11. Remove the supply cable sheath at the length of max. 200 mm.
12. Cut the supply cable conductors to different lengths. Cut the ground conductor longest, so that if a fault occurs it is the last one that comes loose.
13. Strip the supply cable conductors 25 mm.
14. Connect the supply cable wires to the distribution cabinet power connectors.
15. Ensure strain relief to the cable by fastening the cable with e.g. MUPRO EuroQuick. Select a suitable strain relief according to the cable diameter.
16. Connect the supply to the charging points using intervening connection cables. The intervening connection cables are pre-connected to the distribution cabinet power connectors.

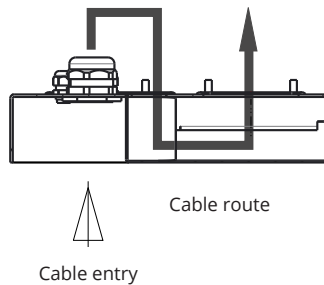

17. Pull the intervening connection cables first down through the mounting box hole on the distribution cabinet side and then up through the mounting box hole on the charging point side.
18. Open the charging point's maintenance door.
19. Lift the charging point module on the mounting box and bolt it in place, max. tightening torque 14 Nm.
20. Connect the intervening connection cable conductors to the supply terminal blocks located in the charging points' maintenance space with max. tightening torque 12 Nm.
21. Ensure that the PE is connected.
22. Switch on F0, F1, F2 (if present) and QF1.
23. Install the second charging point module accordingly.
24. Secure the top cover plate on the charging point and distribution cabinet modules with the washer and screw included in the delivery.
25. Close the maintenance doors.

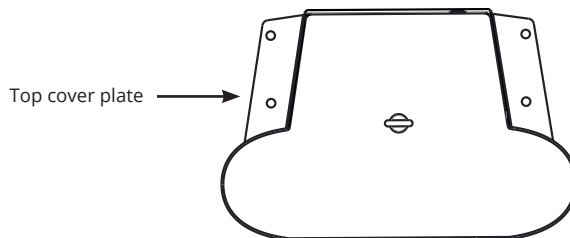

5.8 EVF300 mounting on concrete foundation

Items needed:	Mounting box EVTL35.00	1 pcs
	Adapter for concrete foundation EVTL37.00	1 pcs
	Concrete foundation	1 pcs

This example describes installation procedure using concrete foundation, product code SJR-08, supplied by Sähkö-Jokinen Oy.

If you want to use a foundation manufactured by another supplier, make sure that the foundation is compatible with the adapter.

- Dig a pit for the concrete foundation. The pit floor should be trampled and horizontal.
- Install the foundation, cable pipes (supply and output chaining) and, if necessary, the cable pipe for the data cable into the ground. The pit floor should be trampled and horizontal.
- Fill the pit with gravel. Trample the filling around the foundation to ensure stability.

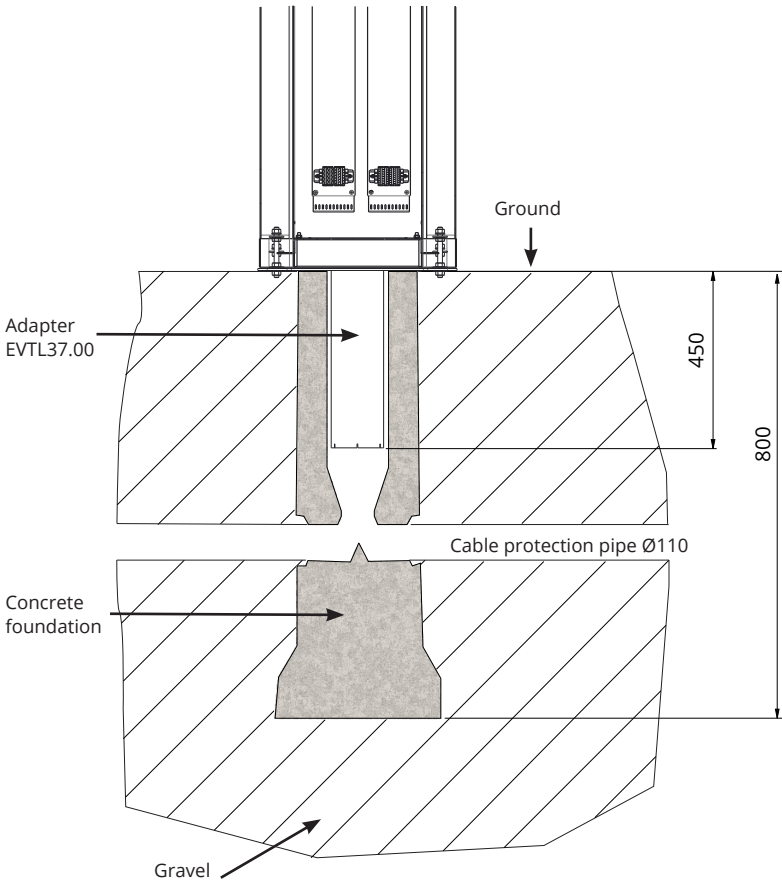

Installation Steps

1. Assemble the concrete foundation adapter.
2. Attach the mounting box EVTL35.00 on the concrete foundation adapter EVTL37.00 and place the assembly on the concrete foundation.
3. Tighten the assembly in place using the screws on the concrete foundation.
4. Pull electrical cables through the ground mounting box cable gland(s) approx. 450 mm measured from the upper surface of the mounting box.
5. Tighten the cable gland. Close the unused cable entries with cable gland plugs.
6. Open the distribution cabinet's maintenance door.
7. Lift the distribution cabinet module on the mounting box and bolt it in place, max. tightening torque 14 Nm.
8. Remove the supply cable sheath at the length of max. 200 mm.
9. Cut the supply cable conductors to different lengths. Cut the ground conductor longest, so that if a fault occurs it is the last one that comes loose.
10. Strip the supply cable conductors 25 mm.
11. Connect the supply cable wires to the distribution cabinet power connectors.
12. Ensure strain relief to the cable by fastening the cable with e.g. MUPRO EuroQuick. Select a suitable strain relief according to the cable diameter.

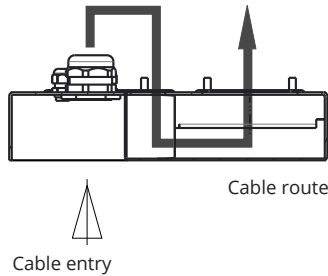

13. Connect the supply to the charging points using intervening connection cables. The intervening connection cables are pre-connected to the distribution cabinet power connectors.
14. Pull the intervening connection cables first down through the mounting box hole on the distribution cabinet side and then up through the mounting box hole on the charging point side.
15. Open the charging point's maintenance door.
16. Lift the charging point module on the mounting box and bolt it in place, max. tightening torque 14 Nm.
17. Connect the intervening connection cable conductors to the supply terminal blocks located in the charging points' maintenance space with max. tightening torque 12 Nm.
18. Ensure that the PE is connected.
19. Switch on F0, F1, F2 (if present) and QF1.
20. Install the second charging point module accordingly.
21. Secure the top cover plate on the charging point and distribution cabinet modules with the washer and screw included in the delivery.
22. Close the maintenance doors.

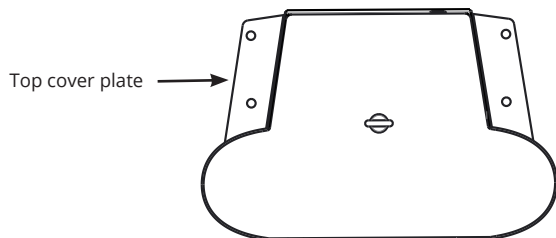

6. Supply Connections

The voltage and current ratings including cables and line protector dimensioning must comply with national regulations. System dimensioning must be done by a qualified electrical designer.

EVF200

Possible supply connections:

- Use separate supply cables for each charging point
- Use one supply cable and chain internally to the charging points

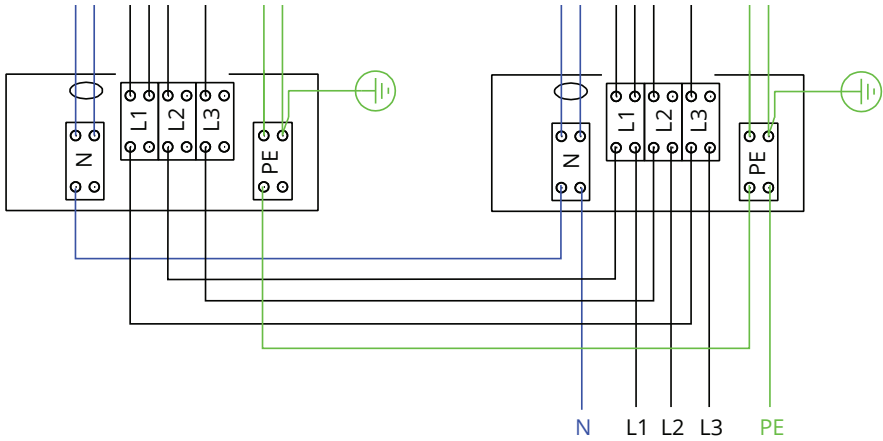

EVF300 Internal Circuit, Main Board Example

The distribution cabinet is delivered empty.

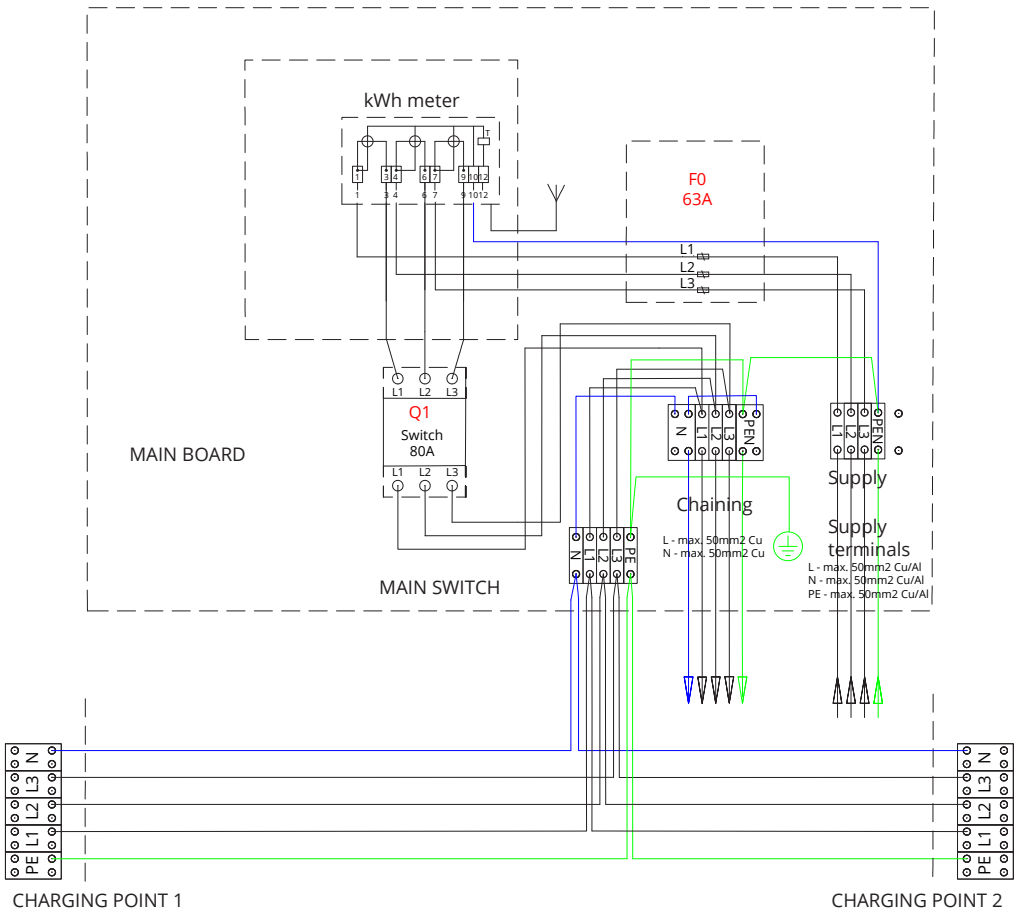
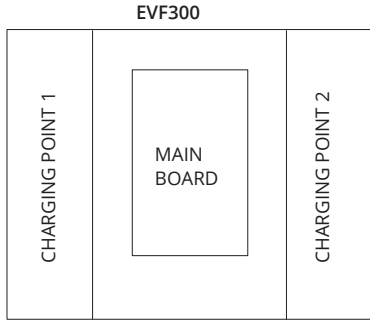

NOTE! If phase rotation is needed, it can be carried out with charging point 1 and 2 supply terminals (L1, L2, L3). The phase rotation should be done in accordance to the electrical plan.

7. Commissioning

Before commissioning the EVF must be installed according to the installation instructions.

By default all EVF products are operating in free charging mode (Standalone operation). In this free charging mode external communication is not active. If the product is going to be connected to some back-office (On-line operation), first make sure that the basic functionality is working before establishing communication. External communication can be implemented via 3G / 4G, optional alternatives Ethernet / Wifi.

7.1 Connecting charging station to external communication

If you want to change the default settings, you must be connected to the controller located inside the charging point via web configuration tool to be able to proceed with the commissioning settings. Use Firefox or Windows Explorer web-browser for configuring.

The image below shows how to connect a computer to the controller with a USB cable. For this purpose a cable with USB A and Micro B ends is needed. (This cable is usually included in the Android mobile phone sales packages).

NOTE! On charging stations with two charging points (EVF200 and EVF300) always connect USB cable to the controller on the right side.

USB Micro B end is connected to the controller.

Insert the USB cable so that the longer edge of the facing is away from you.

Do not remove any existing USB devices from any of the controller units!

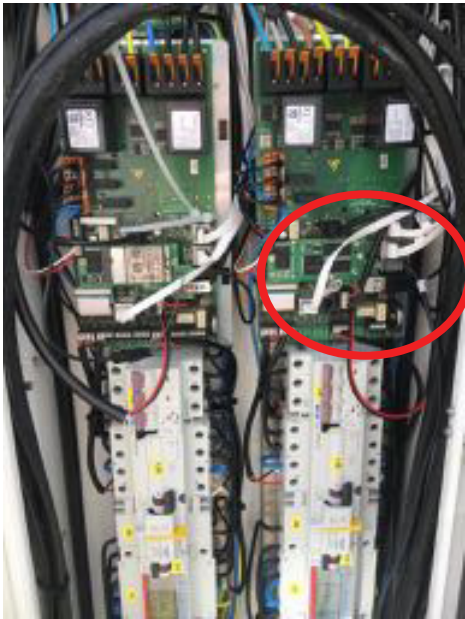

Please see detailed commissioning instructions on <https://ewiki.ensto.technology/>

8. User Instructions

8.1 User Interfaces

LED signal lights will show the status of the charging point as described below:

Charging point status	LED light	LED operation
Charging point free and ready to use	Green	Stable
RFID read, user login ongoing	Green	Flashing
User login fail, access denied	Red	Stable
User login passed, charging allowed	Green	Waving
While connecting the cable	Green	Flashing twice
Vehicle connected, charging not started	Blue	Waving
Vehicle connected, starts charging	Blue	Waving
Charging ongoing	Blue	Stable
Error state	Red	Stable

8.2 Charging

Free charging

- Plug in your electric vehicle to start charging.
- Unplug your electric vehicle to stop charging.

Charging with RFID

You must have an RFID tag which has a permission to access the charging point.

Start Charging with RFID

- When the charging point is free and the indicator light shows green, you can start a charging event.
- Show the RFID tag to the RFID reading area.
- When the RFID tag is read, the charging point will flash green and verify the user permission to charge. If the user login is failed, the indicator light turns to red. If the user login is passed, the indicator light turns to waving green.
- Now you are logged in to the charging point.
- Plug in the electric vehicle for charging. The indicator light turns to stable blue.

Stop Charging with RFID

- Show the RFID tag to the RFID reading area.
- When you stop the charging event, the indicator light turns to waving green and you are able to unplug the charging cable.
- After you have unplugged, you are logged out from the charging point and the charging point is free for the next user.

9. Technical Data

Electrical Connections	EVF100	EVF200	EVF300
Nominal supply voltage	1-ph/3-ph, 230/400VAC		
Nominal frequency	AC 50 Hz		
Nominal supply current	3× 32 A (Mode 3 socket)	3× 63A (Mode 3 socket)	
Charging power (nominal)	22kW 1x 3 x 32A Optional: <ul style="list-style-type: none"> • Domestic socket: 3600W, 1x16A • Dynamic load management (DLM) based on available power • Static current limitation on back-office system (EV Manager) 	22kW per charging outlet, 2x 3 x 32A	
Supply connections and terminals	L1, L2, L3, N, PE Cu 2.5–50 mm ² (according to supply current and local regulations) Tightening torque Nm: 4 Nm (2.5 - 4 mm ²), 12 Nm (6 - 50 mm ²)		

Design and Mechanics	EVF100	EVF200	EVF300
Material	Painted aluminum and stainless steel		
Color	RAL9016S "Traffic White"		
Enclosure class	IP54		
Impact resistance class	IK10		
Operating temperature	-30 °C ... +55 °C		
Standard	IEC 61851-1		
Approvals	CE		

Safety features	EVF100	EVF200	EVF300
Over current protection (MCB)	Default		
Residual current protection (RCD)	Type A (30mA AC) Type B (6mA DC)		
Low control voltage	Default 12 VDC		
Optional features	RCD autoreset RCD remote test Surge, overvoltage protection Automatic release for Mode 3 socket in case of sudden power outage Temperature sensor Tilt sensor		



User Interface	EVF100	EVF200	EVF300
Connection to vehicle	Default: Mode 3, Type 2 Optional: Domestic socket Type F / E / G		
Lockable lid for Domestic socket	Default		
Charging status indication	3-color LED <ul style="list-style-type: none"> • Green / Available • Blue / Charging • Red / Malfunction 		
Simultaneous users	1 user	2 users	2 users
User access and control	Standalone mode (default): <ul style="list-style-type: none"> • Free use, RFID Online mode (optional): <ul style="list-style-type: none"> • RFID reader (ISO/IEC 1443A/B, ISO/IEC 15693) • Mobile phone (SMS, call, app) • Back-office system (EV Manager) 		
Energy measurement	Default: <ul style="list-style-type: none"> • Current transformers (per charging point) Optional: <ul style="list-style-type: none"> • MID class kWh meter (per charging point) 		Optional: A remotely read kWh meter installed in the station by an electricity company

Connectivity and communication	EVF100	EVF200	EVF300
Connectivity	Default: GSM (3G, 4G) Optional: Ethernet, Wifi		
Communication	Default: OCPP 1.5 or OCPP1.6, both fully implemented		

10. Dimension Drawings

EVF100

Ensto Pro with one charging point.

The charging point is placed on the left side seen from the maintenance door.

Note! Domestic socket is optional.

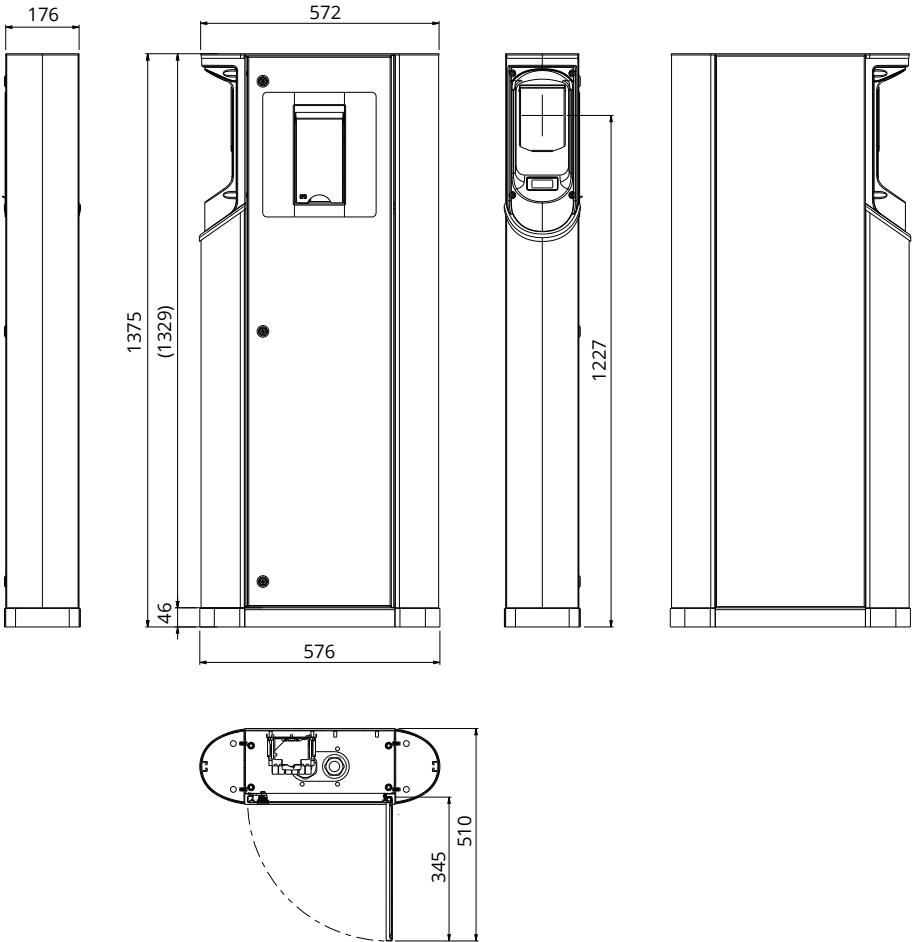

EVF200

Ensto Pro with two charging points.

Note! Domestic sockets are optional.

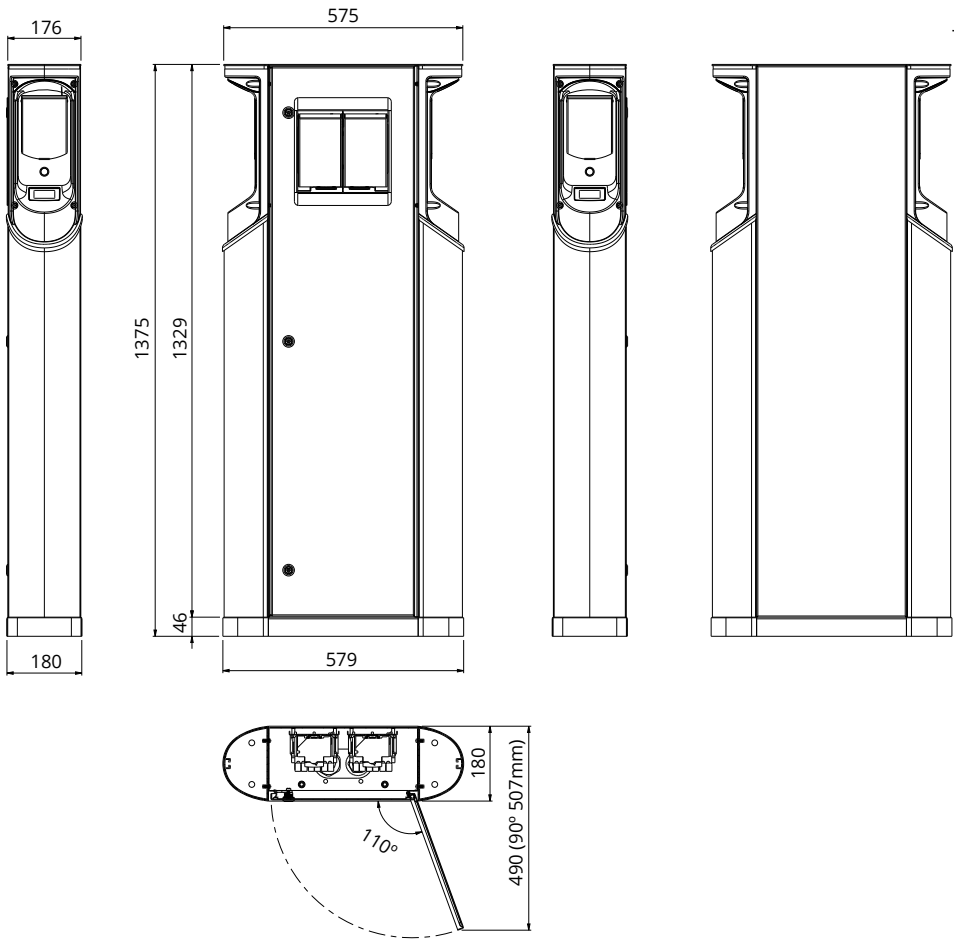

EVF300

Ensto Pro with two charging points and a distribution cabinet.
 Note! Domestic sockets are optional.

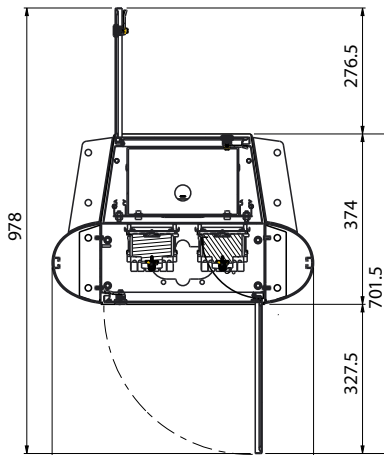
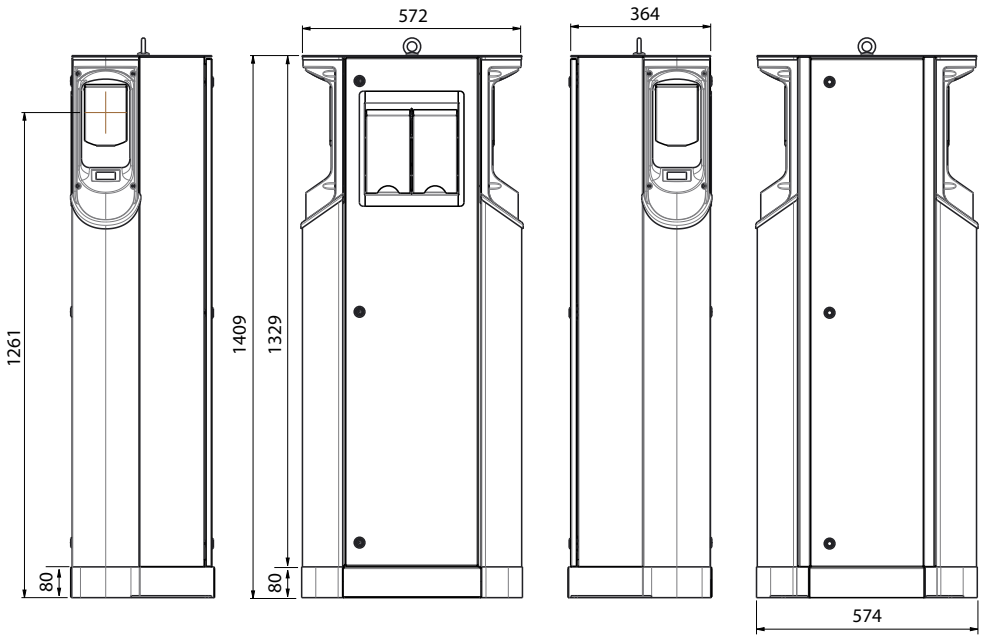

Distribution cabinet	depth 160 mm
Mounting plate inside the cabinet	width 350 mm height 1250 mm

11. Installation / Commissioning Checklist

Introduction

This checklist is a guidance for ensuring both mechanical and electrical installation as well as commissioning of the EVF.

Before Installation

Read the product specific installation instructions before performing any actions.

Note! Only qualified person may perform the installation in accordance with the applicable local and national electrical rules and standards.

Checking the Installation



Go through the visual, mechanical and electrical installation when the charging station is disconnected from mains.

CATEGORY	X	ITEM
Overall look		Ordered material has been received.
		Protective plastic wrapping has been removed.
		No scratches or damages may be seen.
Mechanical installation		Charging station is fixed properly on the ground / wall. Please see details on installation instructions.
		The maintenance doors open and close smoothly.
Electrical installation		Charging point's power supply capacity meets electrical planning (cable size, MCB...). Review local electrical design plan.
		Gently push the charging point with a hand to create vibration to ensure no bad contact / connection exist on wire or PCB.
		Gently push the controller to create vibration to ensure no bad contact / connection exist on wire or PCB.
		Check tightness of the PE-cable screw. The screw is above the supply terminals.
		Power supply cables (L1, L2, L3, N and PE) are properly connected.
		Insulation of power supply cables / conductors is intact (L1, L2, L3, N and PE).
		Voltage between PE and N is less than 10 V.
		PE conductor resistance is less than 3 Ω.
Operational check		All the LED states / colors (green, blue, red) and RFID reader is functioning. Create fail and charge (with RFID tag). Red at bootup, green at idle and blue while charging.
		Available electricity at the sockets. All the contacts (L1, L2, L3) must be tested. Use Mode 3 tester.
		Verify that when charging point's LED is green, there is no power at the socket contact (L1, L2, L3, N).
		Test the functioning of Mode 3; LED colors from green to blue. Use Mode 3 tester.

12. Maintenance / Preventive Maintenance Instructions

1 x per year



WARNING! *Danger of electrical shock or injury.*

Disconnect power before working inside the device or removing any components.

X	MAINTENANCE ACTION
	Retighten all screws (electric components).
	Check the Mode 3 socket. If the socket is damaged, replace it with a new one (socket cost not under warranty).
	Check the sealings.
	Gently push the charging point with a hand to create vibration to ensure no bad contact / connection exist on wire or PCB.
	Gently push the controller to create vibration to ensure no bad contact / connection exist on wire or PCB.
	Create fail and charge (with RFID tag) to check all the LED states / color (green, blue, red) and RFID reader is functioning.
	Test available electricity at the sockets. Use Mode 3 tester. All the contacts (L1, L2, L3) must be tested.
	Test the functioning of Mode 3; LED colors from green to blue. Use Mode 3 tester.
	Check tightness of the PE-cable screw.
	Test voltage between PE and N, must be less than 10 V.
	Test PE conductor resistance, must be less than 3 Ω.
	Test the surge arrester, if there is any.
	SW update if needed (if in service contract).
	Restart the station from F0, ensure it will restart properly.

Maintenance performed by:	Date:
---------------------------	-------

13. EVF100 Internal Wiring Diagram Example

EVF100 has one insert.

EVF200 and EVF300 have two identical inserts, one per charging point. A USB cable is connected between the controllers.

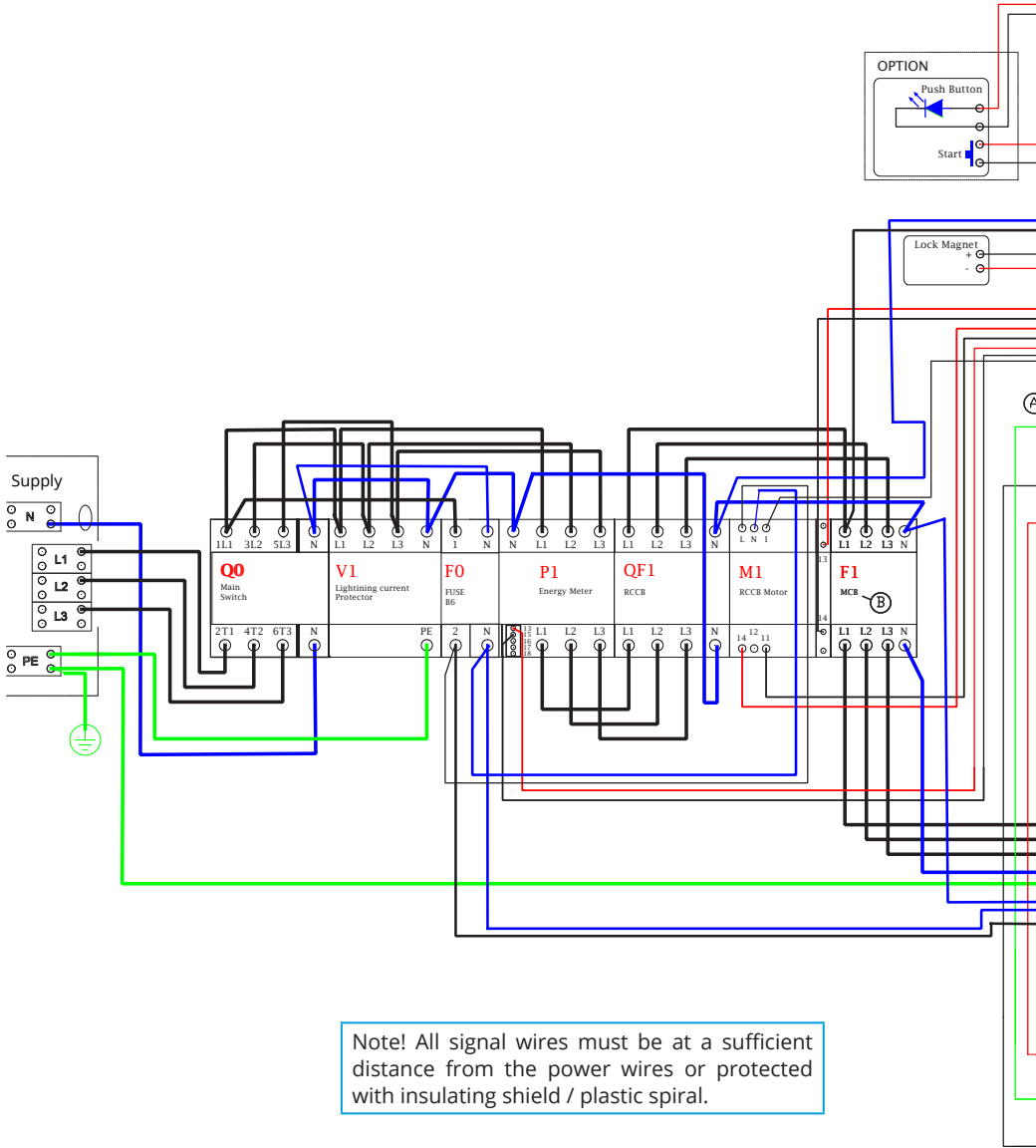

Note! All signal wires must be at a sufficient distance from the power wires or protected with insulating shield / plastic spiral.

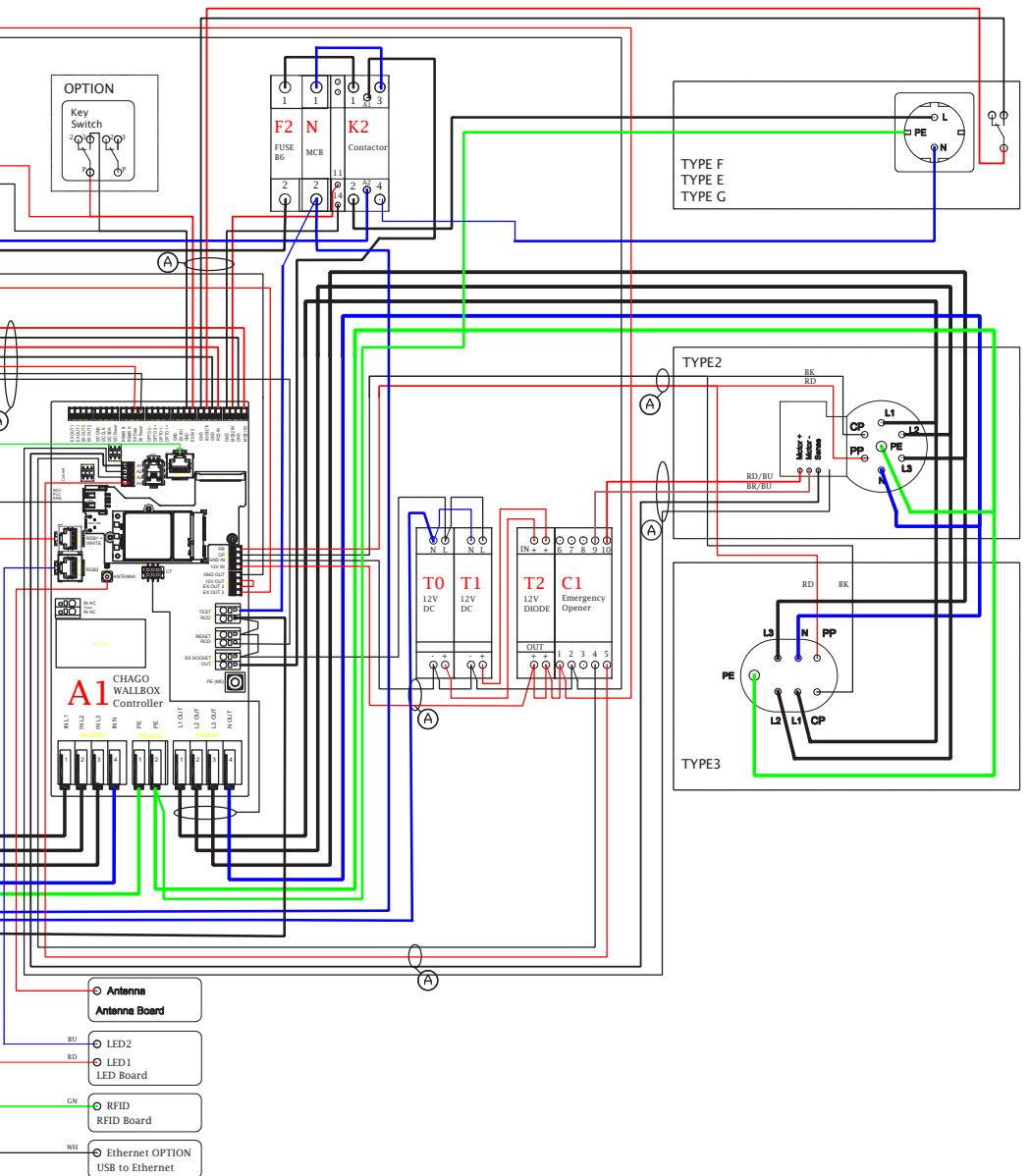

14. Troubleshooting

Charging station is off, no lights on

Issue	Corrective action
Mains voltage does not exist in supply connector L1.	Ensure proper power supply.
Circuit breaker F0 is off.	Turn F0 on.
12V power unit has no LED on.	Ensure 230V power supply to 12V power unit; if ok replace the power unit.
The controller has no PWR LED on.	Ensure power supply to the controller; if ok replace the controller.

Charging cable is locked in Mode 3 socket outlet

Issue	Corrective action
Unexpected fault has occurred while power is on.	Option 1: If equipped with Mode 3 lock release functionality, turn off the power from F0 and pull charging cable out from the socket. Option 2: Turn off the power. Switch Mode 3 lock manually into open position.
Power is off.	Switch Mode 3 lock into open position. Note! If the station has a Mode 3 Lock Release functionality, then during power cut the Mode 3 lock opens automatically.

Configuration via web browser

Issue	Corrective action
PC does not recognize micro USB plug and connection to the controller cannot be established via web browser.	Check from Windows 7 / 10 operating system settings via "Device Manager" that RNDIS network adapter is available. If not, update the related Windows driver.

15. Warranty

Warranty conditions, see the product card on www.ensto.com



ENSTO

Ensto Finland Oy
Ensio Miettisen katu 2, P.O. Box 77
FIN-06101 Porvoo, Finland
Tel. +358 20 47 621
Customer service +358 200 29 007
ensto@ensto.com

