

HOW TO USE THIS MANUAL

GENERAL INFORMATION

010RX-01

1. GENERAL DESCRIPTION

- (a) This manual is written in accordance with SAE J2008.
- (b) Repair operations can be separated into 3 main processes:
 1. Diagnosis
 2. Removing/Installing, Replacing, Disassembling/Reassembling, Checking and Adjusting
 3. Final Inspection
- (c) This manual explains the "Diagnosis" (found in the "Diagnostics" section) and "Removing and Installing, Replacing, Disassembling, Installing and Checking, and Adjusting". "Final Inspection" is omitted.
- (d) The following essential operations are not written in this manual. However, these operations must be performed in actual situations.
 - (1) Operations with a jack or lift
 - (2) Cleaning of a removed part when necessary
 - (3) Visual check
- (e) The "< >" marks highlight the part's name in the Parts Catalog.

2. INDEX

- (a) An alphabetical INDEX section is provided at the end of the book as a reference to help you find the item to be repaired.

3. PREPARATION

- (a) Use of Special Service Tools (SST) and Special Service Materials (SSM) may be required, depending on the repair situation. Be sure to use SST and SSM when they are required and follow the working procedure properly. A list of SST and SSM is in the Preparation section of this manual.

4. REPAIR PROCEDURES

- (a) A component illustration is placed under the title where necessary.
- (b) Non-reusable parts, grease application areas, precoated parts and torque specifications are noted in the component illustrations.

Example:

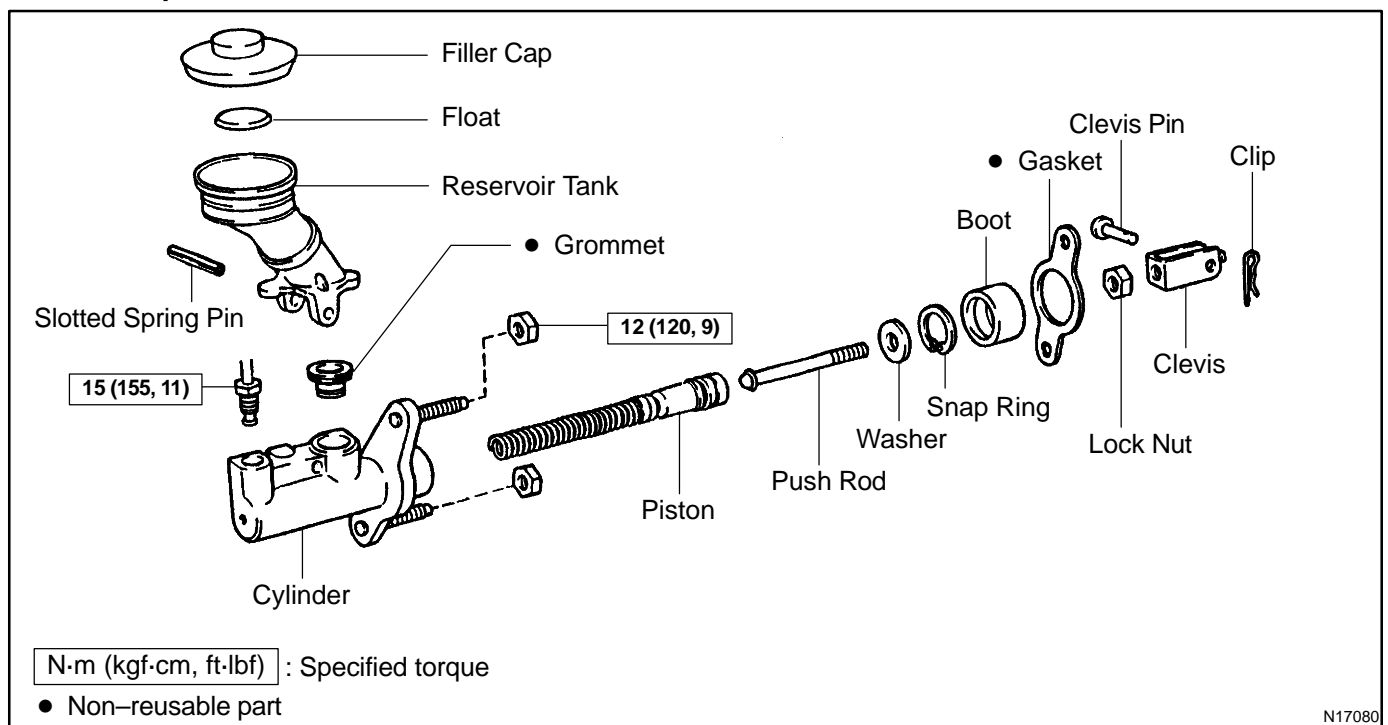

- (c) Torque specifications, grease application areas, and non-reusable parts are emphasized in the procedures.

NOTICE:

There are cases where such information can only be explained by using an illustration. In these cases, all the information such as torque, oil, etc. are described in the illustration.

- (d) The installation procedures are the removal procedures in reverse order. However, only installation procedures requiring additional information are included.
- (e) Only items with key points are described in the text. What to do and other details are placed in illustrations next to the text. Both the text and illustrations are accompanied by standard values and notices.
- (f) Illustrations of similar vehicle models are sometimes used. In those cases, specific details may be different from the actual vehicle.
- (g) Procedures are presented in a step-by-step format:
 - (1) The illustration shows what to do and where to do it.
 - (2) The task heading tells what to do.
 - (3) The explanation text tells how to perform the task. It also has information such as specifications and warnings.

Example:

Illustration:
what to do and where

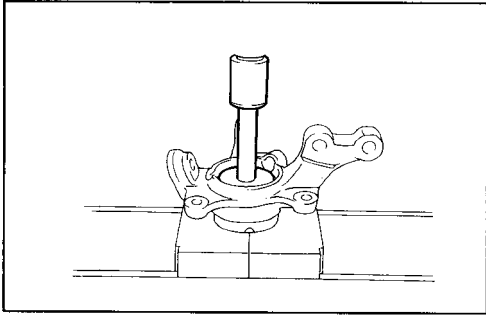

Task heading: what you will be doing

The "< >" marks highlight the part's name in the Parts Catalog

14. INSTALL FRONT AXLE HUB BEARING
<FRONT AXLE HUB BEARING OUTER LH>

(a) Using SST and a press, install a new bearing to the steering knuckle. *Detailed text: how to perform task*

SST **09950-60020 (09951-00720), 09950-70010 (09951-07100)**

Set part No. *Component part No.*

D31332

HINT:

This format provides an experienced technician with a FAST TRACK to the necessary information. The task headings are easy to read and the text below the task heading provides detailed information. Important specifications and warnings are always written in bold type.

5. SERVICE SPECIFICATIONS

- (a) SPECIFICATIONS are presented in bold-faced text throughout the manual. The specifications are also found in the Service Specifications section for quick reference.

6. TERMS DEFINITION

CAUTION	Possibility of injury to you or other people.
NOTICE	Possibility of damage to the components being repaired.
HINT	Provides additional information to help you perform repairs.

7. SI UNIT

- (a) The units used in this manual comply with the SI UNIT (International System of Units) standard. Units from the metric system and the English system are also provided.

Example:

Torque: 30 N·m (310 kgf·cm, 22 ft·lbf)

IDENTIFICATION INFORMATION

VEHICLE IDENTIFICATION AND SERIAL NUMBERS

010RY-01

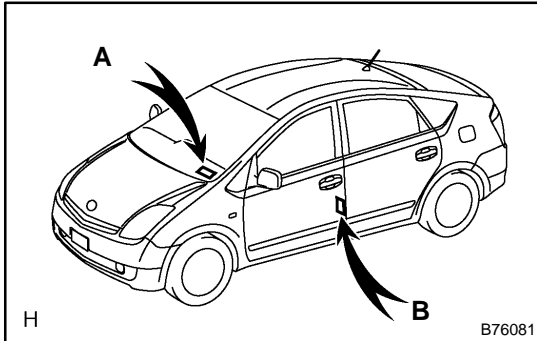

1. VEHICLE IDENTIFICATION NUMBER

- (a) The vehicle identification number is stamped on the vehicle identification number plate and certification label, as shown in the illustration.

A: Vehicle Identification Number Plate

B: Certification Label

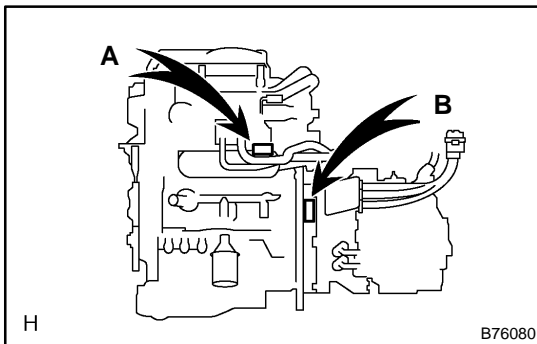

2. ENGINE SERIAL NUMBER AND MOTOR SERIAL NUMBER

- (a) The engine serial number is stamped on the engine block, as shown in the illustration.

A: Engine Serial Number

- (b) The motor serial number is stamped on the motor as shown in the illustration.

B: Motor Serial Number

REPAIR INSTRUCTION

PRECAUTION

010RZ-01

1. BASIC REPAIR HINT

(a) HINTS ON OPERATIONS

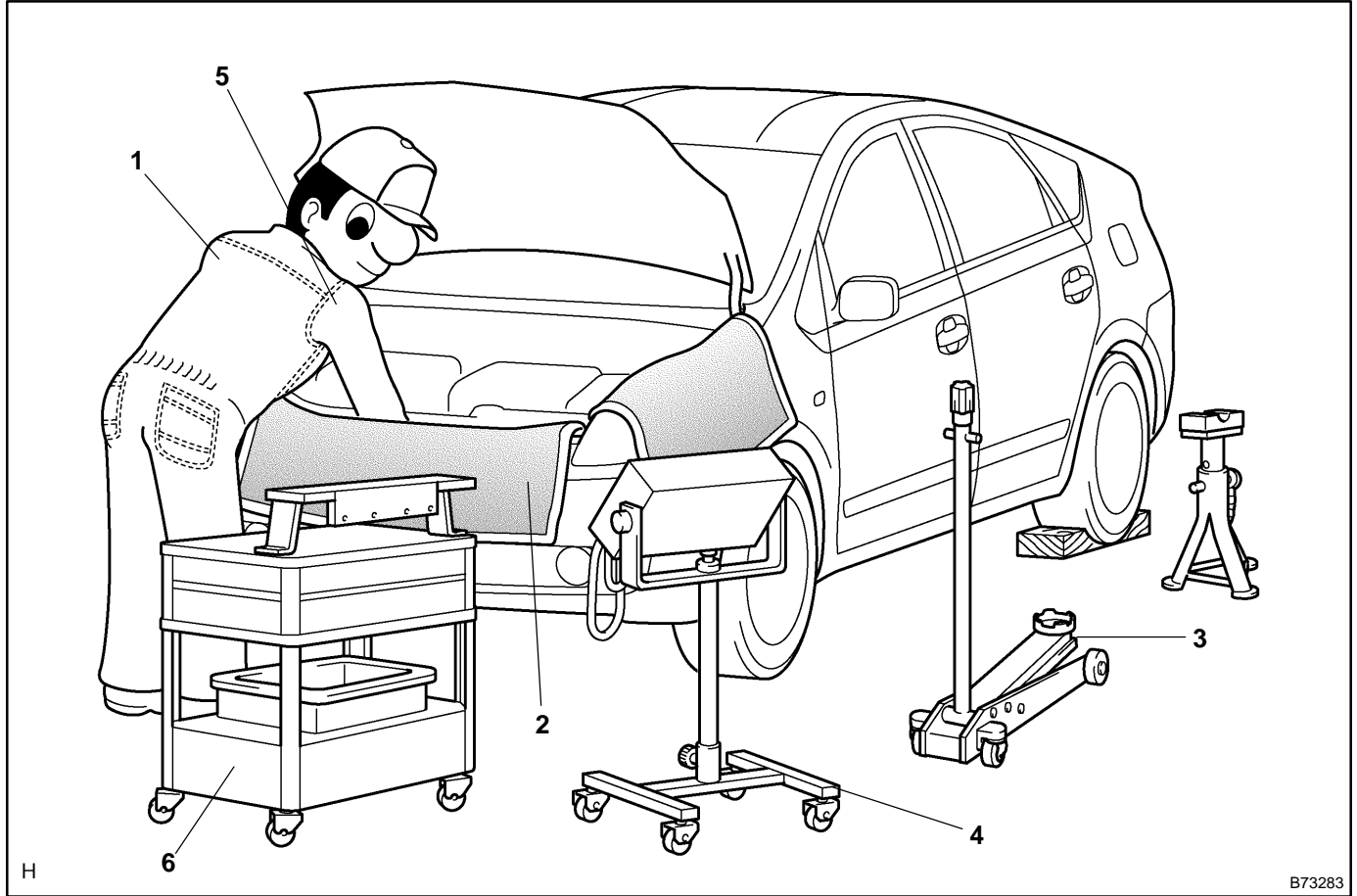

1	Looks	<ul style="list-style-type: none"> ●Always wear a clean uniform. ●A hat and safety shoes must be worn.
2	Vehicle protection	<ul style="list-style-type: none"> ●Prepare a grille cover, fender cover, seat cover and floor mat before starting the repairs.
3	Safe operation	<ul style="list-style-type: none"> ●When working with 2 or more persons, be sure to check safety for one another. ●When working with the engine running, make sure to provide ventilation for exhaust fumes in the workshop. ●If working on high temperature, high pressure, rotating, moving, or vibrating parts, wear appropriate safety equipment and take extra care not to injure yourself or others. ●When jacking up the vehicle, be sure to support the specified location with a safety stand. ●When lifting up the vehicle, use appropriate safety equipment.
4	Preparation of tools and measuring gauge	<ul style="list-style-type: none"> ●Before starting operation, prepare a tool stand, SST, gauge, oil, shop rag and parts for replacement.
5	Removal and installation, disassembly and assembly operations	<ul style="list-style-type: none"> ●Diagnose with a thorough understanding of proper procedures and of the reported problem. ●Before removing the parts, check the general condition of the assembly and for deformation and damage. ●When the assembly is complicated, take notes. For example, note the total number of electrical connections, bolts, or hoses removed. Add matchmarks to insure re-assembly of components in the original positions. Temporarily mark hoses and their fittings, if needed. ●Clean and wash the removed parts if necessary and assemble them after a thorough check.
6	Removed parts	<ul style="list-style-type: none"> ●Place the removed parts in a separate box to avoid mixing them up with the new parts or contaminating the new parts. ●For non-reusable parts such as a gasket, O-ring, and self-locking nut, replace them with new ones following the instructions in this manual. ●Retain the removed parts for customer inspection, if requested.

(b) JACKING UP AND SUPPORTING VEHICLE

- (1) Care must be taken when jacking up and supporting the vehicle. Be sure to lift and support the vehicle at the proper locations (see page 01-34).

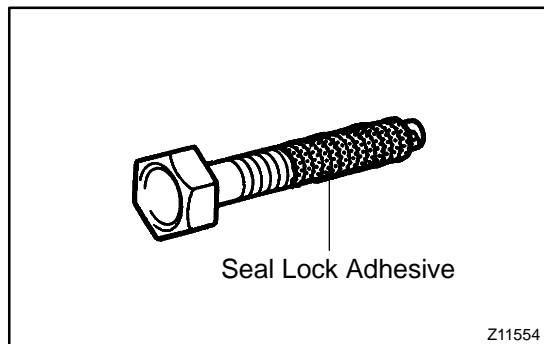

(c) PRECOATED PARTS

- (1) Precoated parts are bolts and nuts that are coated with a seal lock adhesive at the factory.
- (2) If a precoated part is retightened, loosened or moved in anyway, it must be recoated with the specified adhesive.
- (3) When reusing precoated parts, clean off the old adhesive and dry the part with compressed air. Then apply new seal lock adhesive appropriate to the bolts and nuts.

NOTICE:

Perform the torque with the lower limit value of the torque tolerance.

- (4) Some seal lock agents harden slowly. You may have to wait for the seal lock agent to harden.

(d) GASKETS

- (1) When necessary, use a sealer on gaskets to prevent leaks.

(e) BOLTS, NUTS AND SCREWS

- (1) Carefully follow all the specifications for tightening torques. Always use a torque wrench.

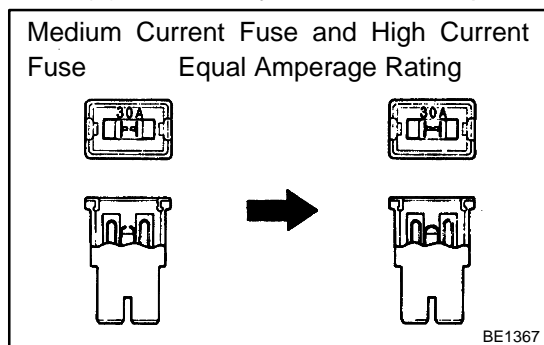

(f) FUSES

- (1) When replacing fuses, be sure that the new fuse has the correct amperage rating. DO NOT exceed the rating or use one with a lower rating.

Illustration	Symbol	Part Name	Abbreviation
<p style="text-align: right;">BE5594</p>	<p style="text-align: right;">IN0365</p>	FUSE	FUSE
<p style="text-align: right;">BE5595</p>	<p style="text-align: right;">IN0366</p>	MEDIUM CURRENT FUSE	M-FUSE
<p style="text-align: right;">D27353</p>	<p style="text-align: right;">IN0367</p>	HIGH CURRENT FUSE	H-FUSE

(g) CLIPS

- (1) The removal and installation methods of typical clips used in body parts are shown in the table below.

HINT:

If clips are damaged during a procedure, always replace the damaged clip with a new clip.

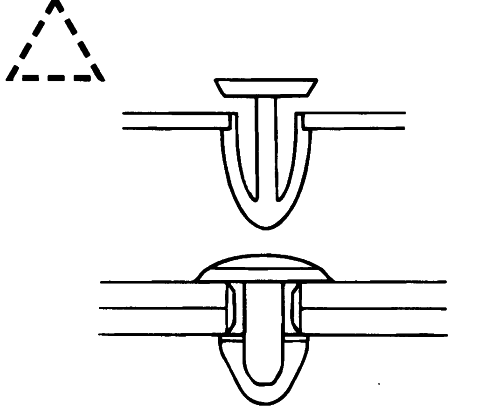
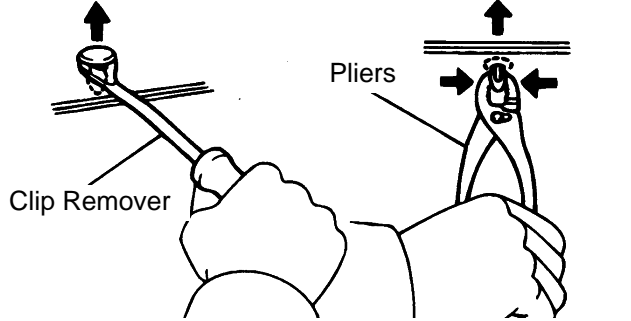
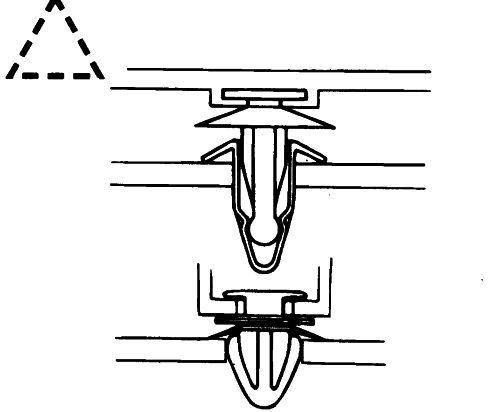
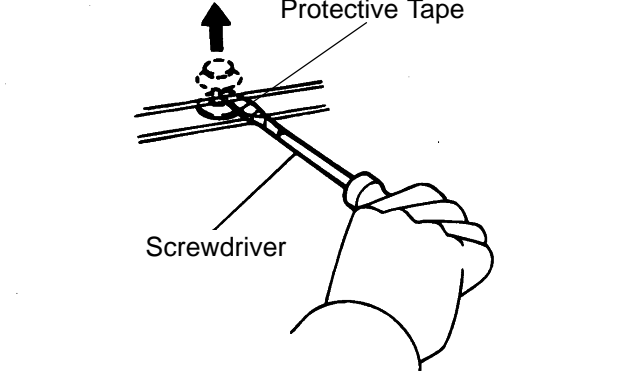
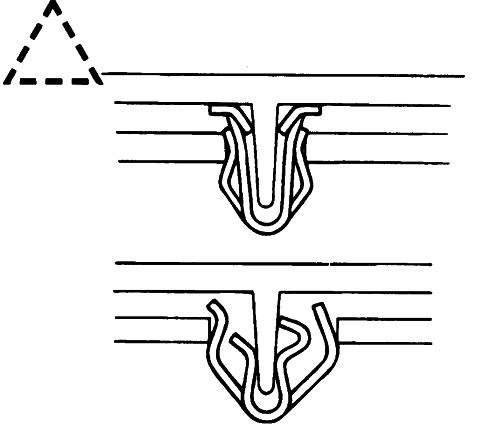
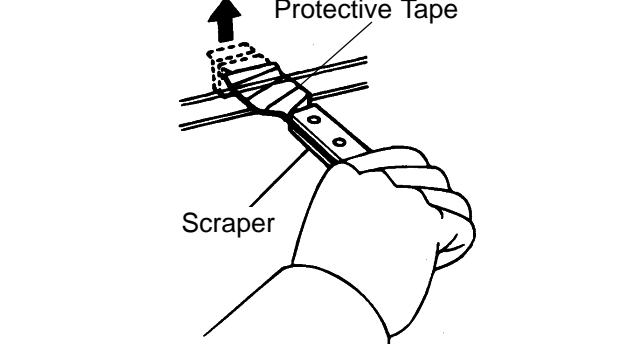
Shape (Example)	Removal/Installation
	 <p>Remove clips from front or rear using clip remover or pliers.</p>
	 <p>Remove fasteners with a clip remover or screwdriver.</p>
	 <p>Remove clips with a wide scraper to prevent panel damage.</p>

D25786

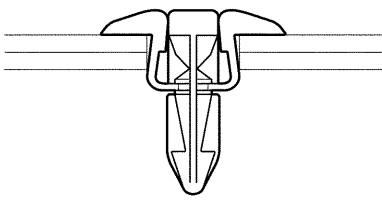
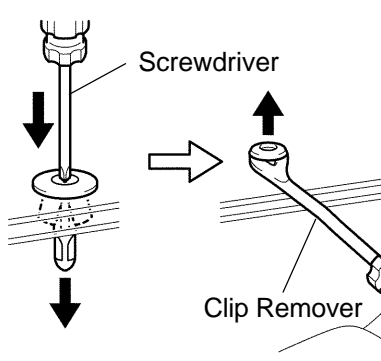
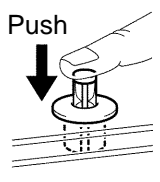
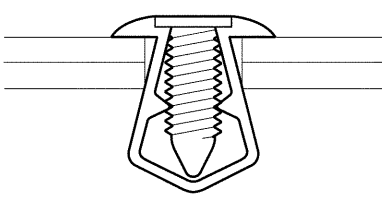
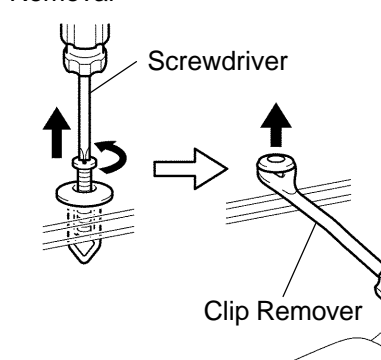
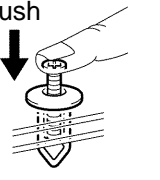
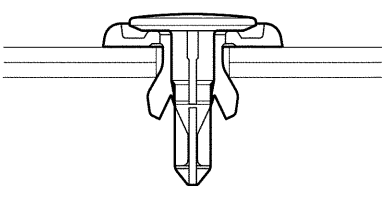
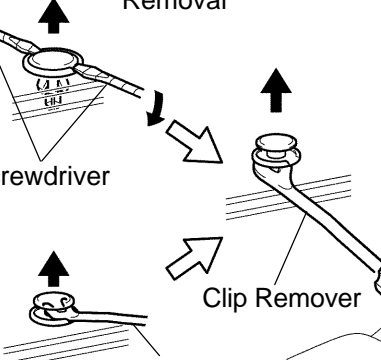
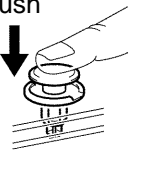
Shape (Example)	Removal/Installation	
	<p>Removal</p>  <p>Screwdriver</p> <p>Clip Remover</p>	<p>Installation</p>  <p>Push</p>
	<p>Removal</p>  <p>Screwdriver</p> <p>Clip Remover</p>	<p>Installation</p>  <p>Push</p>
	<p>Removal</p>  <p>Screwdriver</p> <p>Clip Remover</p> <p>Small Clip Remover</p>	<p>Installation</p>  <p>Push</p>

P

V35006

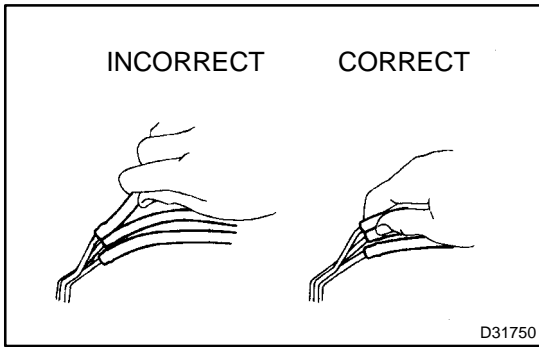

- (h) REMOVAL AND INSTALLATION OF VACUUM HOSES
- (1) To disconnect vacuum hoses, pull and twist from the end of the hose. Do not pull from the middle of the hose as this may cause damage.

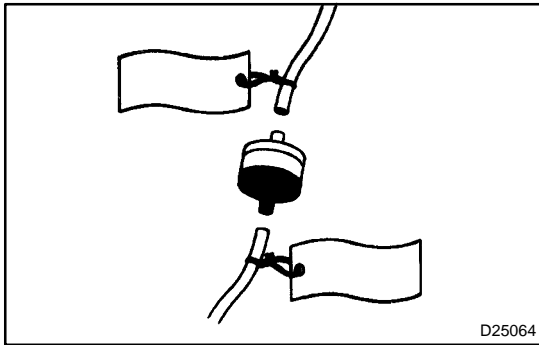

- (2) When disconnecting vacuum hoses, use tags to identify where they should be reconnected.
- (3) After completing the job, double check that the vacuum hoses are properly connected. The label under the hood shows the proper layout.
- (4) When using a vacuum gauge, never force the hose onto a connector that is too large. Use a step-down adapter for adjustment. Once a hose has been stretched, it may leak air.

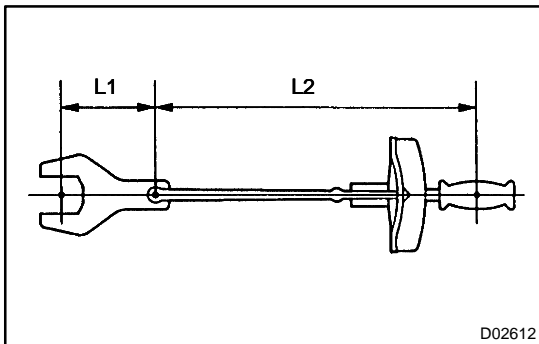

- (i) TORQUE WHEN USING TORQUE WRENCH WITH EXTENSION TOOL

- (1) If SST or an extension tool is combined with the torque wrench to extend its length, do not tighten the torque wrench to the specified torque values in this manual. The resulting torque will be excessive.
- (2) Use the formula below to calculate special torque values for situations where SST or an extension tool is combined with the torque wrench.
- (3) Formula: $T' = T \times L2 / (L1 + L2)$

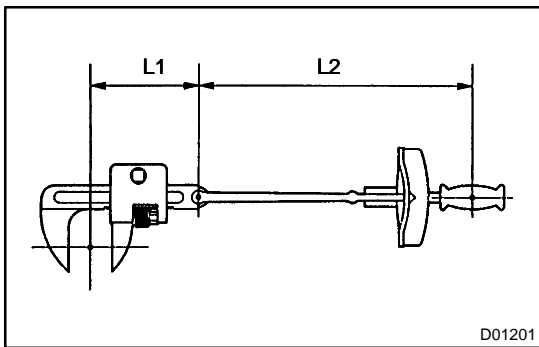

T'	Reading of torque wrench {N·m (kgf·cm, ft·lbf)}
T	Torque {N·m (kgf·cm, ft·lbf)}
L1	Length of SST or extension tool (cm)
L2	Length of torque wrench (cm)

2. PRECAUTIONS FOR HIGH-VOLTAGE CIRCUIT INSPECTION AND SERVICE

- (a) Engineer must undergo special training to be able to perform high-voltage system inspection and servicing.
- (b) All high-voltage wire harness connectors are colored orange. The HV battery and other high-voltage components have "High Voltage" caution labels. Do not carelessly touch these wires and components.

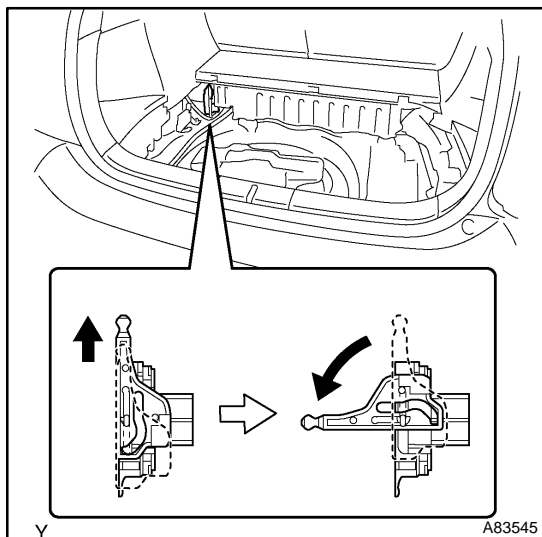

- (c) Before inspecting or servicing the high-voltage system, be sure to follow safety measures, such as wearing insulated gloves and removing the service plug to prevent electrocution. Carry the removed service plug in your pocket to prevent other technicians from reinstalling it while you are servicing the vehicle.
- (d) After removing the service plug, wait 5 minutes before touching any of the high-voltage connectors and terminals.

HINT:

5 minutes are required to discharge the high-voltage condenser inside the inverter.

- (e) Be sure to install the service plug before starting the hybrid system. Starting the hybrid system with the service plug removed may damage the vehicle.

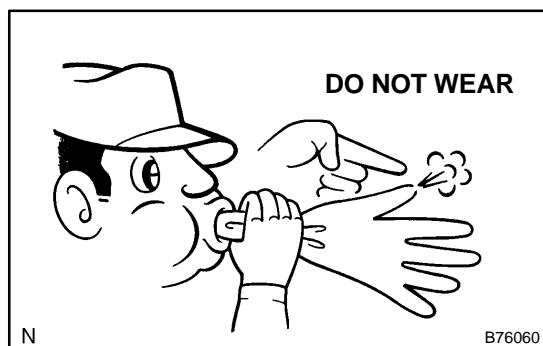

- (f) Before wearing insulated gloves, make sure that they are not cracked, ruptured, torn, or damaged in any way. Do not wear wet insulated gloves.
- (g) When servicing the vehicle, do not carry metal objects like mechanical pencils or scales that can be dropped accidentally and cause a short circuit.
- (h) Before touching a bare high-voltage terminal, wear insulated gloves and use an electrical tester to ensure that the terminal is not charged with electricity (approximately 0 V).

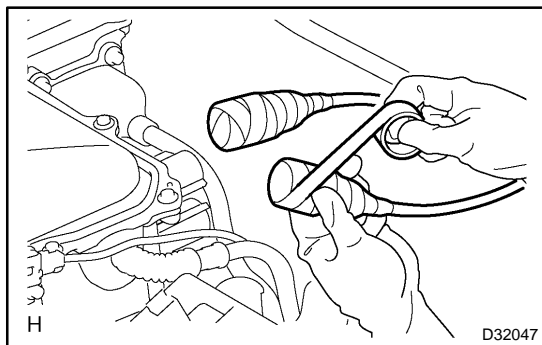

- (i) After disconnecting or exposing a high-voltage connector or terminal, insulate it immediately using insulation tape.
- (j) The screw of a high-voltage terminal should be tightened firmly to the specified torque. Both insufficient and excessive torque can cause failure.
- (k) Use the "CAUTION: HIGH VOLTAGE. DO NOT TOUCH DURING OPERATION" sign to notify other engineers that a high-voltage system is being inspected and/or repaired.
- (l) Do not place the battery upside down while removing and installing it.

- (m) After servicing the high-voltage system and before reinstalling the service plug, check again that you have not left a part or tool inside, that the high-voltage terminal screws are firmly tightened, and that the connectors are correctly connected.

Person in charge: _____

**CAUTION:
HIGH VOLTAGE. DO
NOT TOUCH DURING
OPERATION.**

**CAUTION:
HIGH VOLTAGE. DO
NOT TOUCH DURING
OPERATION.**

Person in charge: _____

Copy this page and put it after folding on the roof of the vehicle in service.

B75514

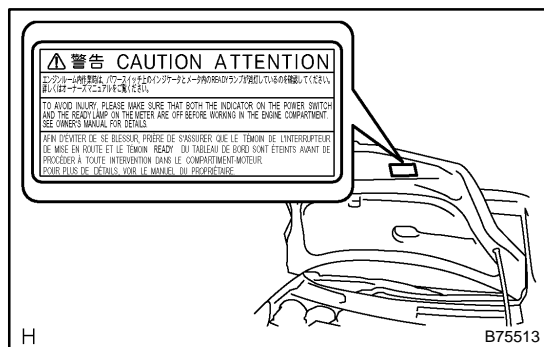

3. PRECAUTIONS TO BE OBSERVED WHEN INSPECTING OR SERVICING ENGINE COMPARTMENT

The PRIUS automatically turns the engine ON and OFF when the READY light on the instrument panel is ON. To avoid injury, remove the key from the key slot before inspecting or servicing the engine compartment.

4. ACTIONS TO BE TAKEN WHEN BATTERIES ARE DEPLETED

- (a) Perform this procedure when the auxiliary battery is fully depleted.

HINT:

The following problems indicate that the auxiliary battery is depleted:

- No display appears on the instrument panel when the power switch's power mode is set to ON (IG).
- The hybrid system does not start.
- The headlights are dim.
- The sound from the horn is weak.

NOTICE:

Never use a quick charger.

- (1) Push the "P" position switch, and engage the parking brake.
- (2) Remove the key from the key slot.
- (3) Using a booster cable, connect the 12 V battery of the rescue vehicle and auxiliary battery of the stalled vehicle, as shown in the illustration.
- (4) Start the engine of the rescue vehicle and run the engine at a speed slightly higher than the idling speed for 5 minutes to charge the auxiliary battery of the stalled vehicle.
- (5) Depress the brake pedal and push the power switch to start the hybrid system.

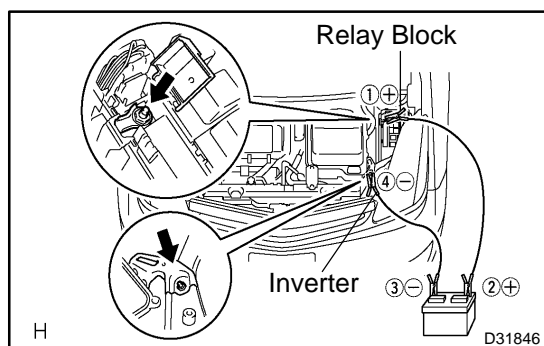

If the hybrid system fails to start and the master lamp turns ON, the HV battery may be depleted.

- (6) Disconnect the booster cable in the reverse order of the connection procedure.

NOTICE:

If the auxiliary battery needs to be replaced, replace it only with a 12 V battery specially designed for use with the PRIUS.

- (b) Perform this procedure when the HV battery is depleted.

NOTICE:

Leaving the vehicle untouched for 2 to 3 months may deplete the HV battery. If the battery is fully depleted, replace the HV battery.

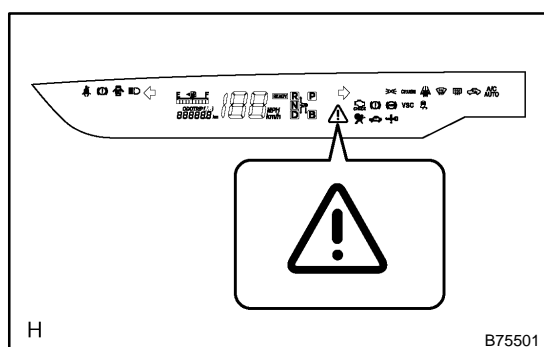

5. INSPECTION MODE

HINT:

- The PRIUS' engine automatically stops if the vehicle is stopped, the engine is warmed up, the battery is well charged, and A/C compressor operation is not being used. Activate inspection mode when continuous operation of the engine is required.
 - The PRIUS has a motor TRAC function. When the wheel speed of the front wheels exceeds that of rear wheels, the wheel speed of the front wheels is restrained. It is necessary to activate inspection mode and deactivate the motor TRAC function when turning only the front wheels using a speedometer tester.
- (a) Vehicle conditions
- (1) Before activating inspection mode, turn the air conditioning off, start the engine with the selector lever in the P position, and check that the engine stops within several seconds after starting (engine warm up check).
 - (2) Activate inspection mode and inspect the vehicle. The shift position for each test is as follows:

Test item	Shift position	Inspection mode
1. Vehicle straight travelling test (side slip inspection)	D	ON or OFF
2. Breaking force test	N	ON or OFF
3. Speed meter test	D	ON
4. Exhaust gas test (idling)	P	ON
5. Headlight test	P	ON or OFF

- (3) Reset inspection mode immediately after completion of inspection.

NOTICE:

Driving the vehicle without resetting inspection mode may damage the transaxle.

- (b) Special notes for speedometer test

NOTICE:

Do not use the speedometer tester to perform rapid starting or quick acceleration/deceleration without first setting the proper load on the vehicle. Failing to set the load may damage the transaxle.

- (1) Depress the accelerator pedal slowly and gradually accelerate the vehicle. Make a measurement.
 - (2) After the measurement, use the brake to gradually decelerate the vehicle.
- (c) Special note for using the chassis dynamometer
Always set an appropriate load before starting the test.

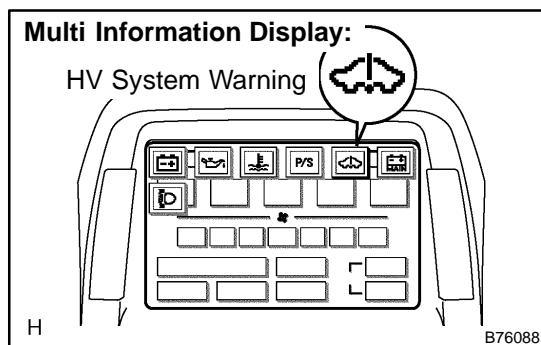

- (d) Activating of inspection mode (Using the hand-held tester)
- (1) Connect the hand-held tester to the DLC3.
 - (2) Push the power switch twice without depressing the brake pedal and change the power mode to ON (IG).
 - (3) Turn the hand-held tester ON.
 - (4) On the hand-held tester, select the item: DIAGNOSIS / ENHANCED OBD II / HV ECU / ACTIVE TEST / INSPECTION MODE / ON.

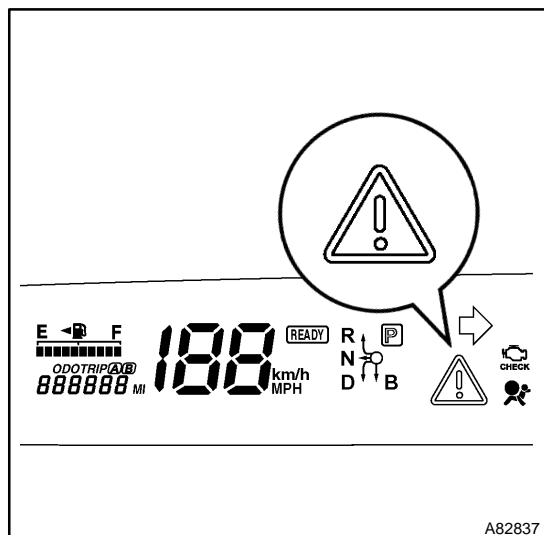

- (5) Activate inspection mode. Check that the HV system warning on the multi-information display starts blinking and master warning lamp on the combination meter is illuminated.
 - (6) Depress and hold the brake pedal, and then push the power switch. The vehicle's engine should run continuously without stopping.
- (e) Deactivating inspection mode
- (1) Change the power switch's power mode to OFF. Inspection mode and the main system (HV system) are turned off simultaneously.

NOTICE:

- The idle speed in inspection mode is approximately 1,000 rpm. The number of revolutions will increase to: 1) 1,500 rpm if the accelerator pedal is less than 60 % depressed, and 2) 2,500 rpm if the pedal is more than 60% depressed.
- If a diagnosis code is recorded when entering inspection mode, the master lamp and the error warning lamp on the multi-center display are illuminated.
- When the master warning light is illuminated during operation in inspection mode, deactivate inspection mode and inspect the diagnosed area.
- Traveling on a road without resetting inspection mode may damage the transaxle.

HINT:

Depress and hold the brake pedal, and then push the power switch. The vehicle's engine should run continuously without stopping.

6. ACTIONS TO BE TAKEN FOR VEHICLE DAMAGED BY IMPACT

- (a) Items to be prepared or operation at the site of the accident
 - Protective clothing (insulated gloves, rubber gloves, goggles, and safety shoes)
 - Saturated boric acid solution 20 L (obtain 800 g of boric acid powder, put it into a container, and dissolve it in water)
 - Red litmus paper
 - ABC fire extinguisher (effective against both oil flames and electrical flames)
 - Shop rags (for wiping off the electrolyte)
 - Vinyl tape (for insulating cable)
 - Electrical tester
- (b) Actions to be taken at the place of accident
 - (1) Wear insulated or rubber gloves, goggles and safety shoes.
 - (2) Do not touch a bare cable that could be a high voltage cable. If the cable must be touched or if accidental contact is unavoidable, follow these instructions: 1) wear insulated or rubber gloves and goggles, 2) measure the voltage between the cable and the body ground using an electrical tester, and 3) insulate the cable using vinyl tape.
 - (3) If the vehicle catches on fire, use an ABC fire extinguisher to extinguish the fire. Trying to extinguish a fire using only a small amount of water can be more dangerous than effective. Use a substantial amount of water or wait for firefighters.

- (4) Visually check the HV battery and immediate area for any electrolyte leakage. Do not touch any leaked liquid because it could be highly alkaline electrolyte. Wear rubber gloves and goggles, and then apply red litmus paper to the leak. If the paper turns blue, the liquid must be neutralized before wiping. Neutralize the liquid using the following procedures:
 - 1) apply saturated boric acid solution to the liquid, and 2) reapply red litmus paper and make sure it does not turn blue. Repeat steps 1 and 2 above until the paper does not turn blue. Then, wipe the neutralized liquid with a shop rag.
- (5) If damage to any of the high-voltage components and cables is suspected, cut the high-voltage circuit using the procedure on the following pages.

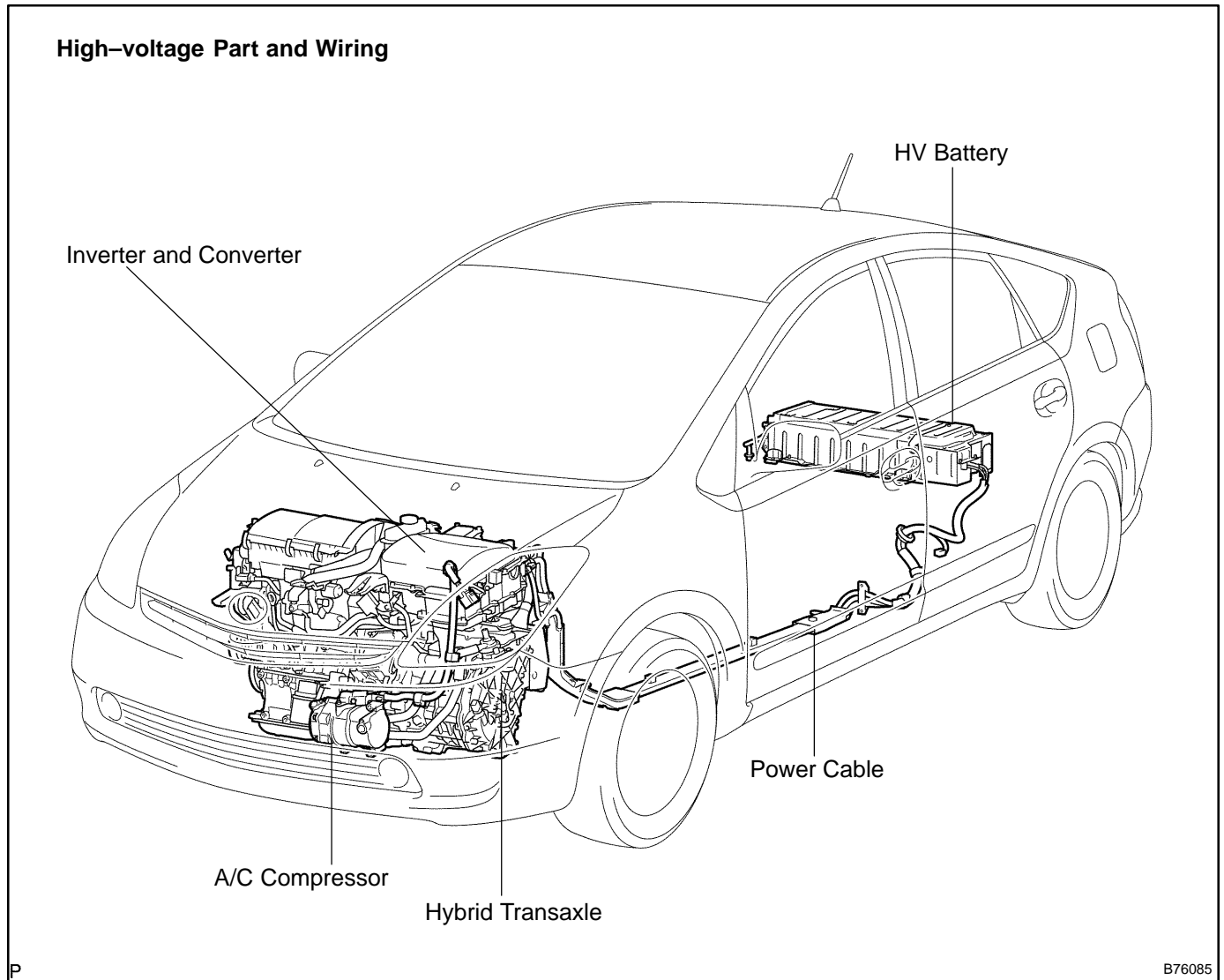

- Push the "P" position switch and engage the parking brake.
- Remove the key from the key slot. Then disconnect the negative (–) terminal of the auxiliary battery.

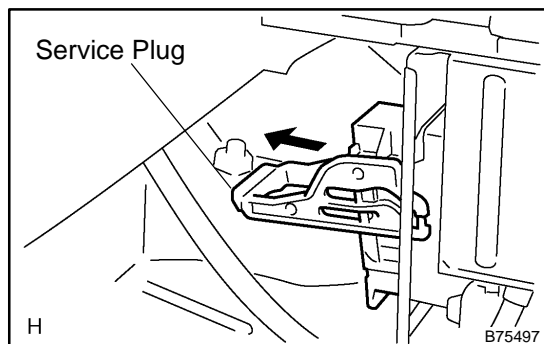

- Remove the service plug while wearing insulated gloves.
- Do not turn the power switch on while removing the service plug.

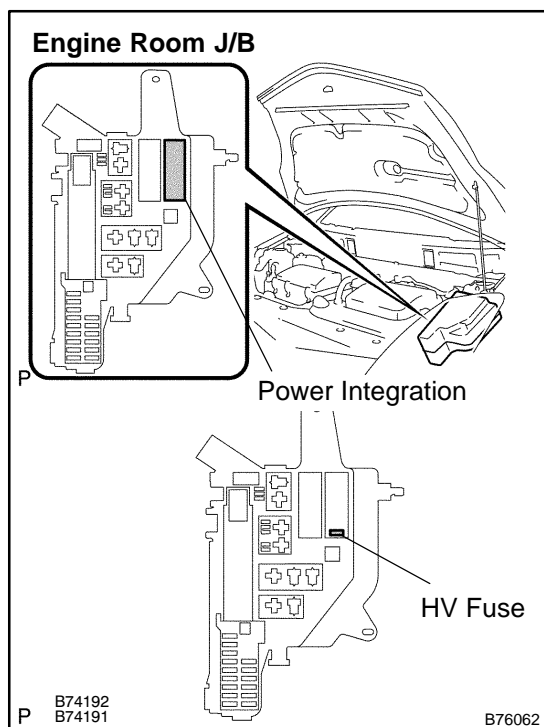

- If the service plug cannot be removed due to damage to the rear portion of the vehicle, remove the HV fuse or power integration (IGCT Relay) instead.

(c) Moving the damaged vehicle

HINT:

If any of the following applies, tow the vehicle away using a tow truck.

- One or more of the high-voltage components and cables are damaged.
- The driving, traction, or fuel system is damaged.

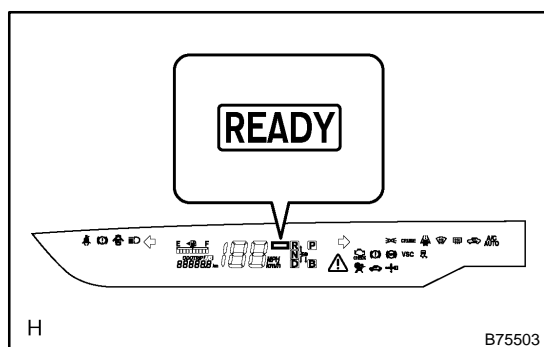

- The READY lamp is not illuminated when you turn.

NOTICE:

- **Before towing the vehicle away using a tow truck, disconnect the cable from the negative (–) terminal of the auxiliary battery and remove the service plug. Only if none of the above applies and there are no problems that might affect driving, drive the vehicle away from the place of accident to a safe, nearby place.**
- **Perform the procedure below if the READY lamp turns off, or there are abnormal noises, unusual smells, or strong vibrations while driving:**
 - (1) Park the vehicle in a safe place.
 - (2) Push the "P" position switch and engage the parking brake.
 - (3) Disconnect the power cable from the negative (–) terminal of the auxiliary battery.
 - (4) Remove the service plug while wearing insulated gloves.

- (d) Actions required after moving the damaged vehicle
If you see any liquid on the road surface, it could be highly alkaline electrolyte leakage.
Wear rubber gloves and goggles, and apply red litmus paper to the leak. If the paper turns blue, the liquid must be neutralized before wiping. Neutralize the liquid using the following procedures: 1) apply saturated boric acid solution to the liquid, and 2) red litmus paper and make sure it does not turn blue. Repeat steps 1 and 2 above until the paper does not turn blue. Then wipe the neutralized liquid with a shop rag.
- (e) Items to be prepared (when repairing damaged vehicles)
- Protective clothing (Insulated gloves, rubber gloves, goggles, and safety shoes)
 - Saturated boric acid solution 20 L (obtain 800 g of boric acid powder, put it into a container, and dissolve it in water)
 - Red litmus paper
 - Shop rags (for wiping off the electrolyte)
 - Vinyl tape (for insulating cable)
 - Electrical tester
- (f) Precautions to be observed when servicing the damaged vehicle
- (1) Wear insulated or rubber gloves, goggles, and safety shoes.
 - (2) Do not touch a bare cable that could be a high voltage cable. If the cable must be touched or if accidental contact is unavoidable, follow these instructions: 1) wear insulated or rubber gloves and goggles, 2) measure the voltage between the cable and the body ground using an electrical tester, and 3) insulate the cable using vinyl tape.
 - (3) Check the HV battery and immediate area for any electrolyte leakage. Do not touch any leaked liquid because it could be highly alkaline electrolyte. Wear rubber gloves and goggles, and then apply red litmus paper to the leak. If the paper turns blue, the liquid must be neutralized before wiping. Neutralize the liquid using the following procedures:
1) apply saturated boric acid solution to the liquid, and 2) reapply red litmus paper and make sure it does not turn blue. Repeat steps 1 and 2 above until the paper does not turn blue, Then wipe the neutralized liquid with a shop rag.
 - (4) If the electrolyte adheres to your skin, wash the skin immediately using saturated boric acid solution or a large amount of water. If the electrolyte adheres to an article of clothing, take it off immediately.

- (5) If the electrolyte comes in contact with your eyes, call out loudly for help. Do not rub your eyes. Wash them with a large amount of water and seek medical care immediately.
- (6) If damage to any of the high-voltage components and cables is suspected, cut the high-voltage circuit using the procedure below.
- Push the "P" position switch and engage the parking brake.
 - Remove the key from the key slot. Then disconnect the power cable from the negative (-) terminal of the auxiliary battery.
 - Wear insulated gloves, and then remove the service plug.
 - If you cannot remove the service plug due to damage to the rear portion of the vehicle, remove the HV fuse or IGCT relay instead.
- (g) Precautions to be taken when disposing of the vehicle
When scrapping the vehicle, remove the HV battery from the vehicle and return it to the location specified by the manufacturer. The same applies to any damaged HV battery.
- (h) After removing the battery, keep it away from water. Water may heat the battery, which results in fire.
- (i) Precautions to be observed when towing
Tow the damaged vehicle with its front wheels or its front and rear wheels lifted off the ground.

NOTICE:

Towing the damaged vehicle with its front wheels on the ground may cause the motor to generate electricity. This electricity could, depending on the nature of the damage, leak and cause a fire.

- (j) Towing with 4 wheels on the ground

NOTICE:

- **If the damaged vehicle needs to be towed using a rope, do not exceed 30 km/h and tow only for very short distances. For example, towing from the accident site to a nearby tow truck is permissible.**
- **Change the power switch's power mode to ON (IG) and shift the selector lever to the N position.**
- **If any abnormality is present in the damaged vehicle during towing, stop towing immediately.**

- (k) Towing eyelet
- (1) Install the hook.
 - (2) Hook a rope on to the illustrated area for towing.

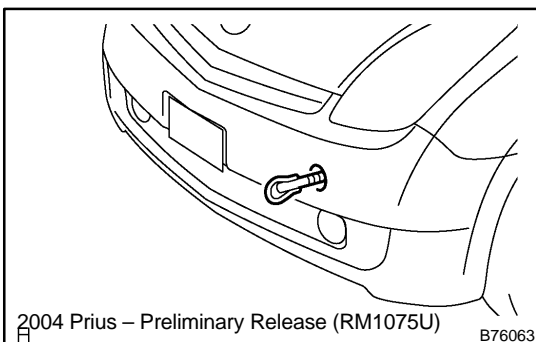

7. FOR VEHICLES EQUIPPED WITH SRS AIRBAG AND SEAT BELT PRETENSIONER

HINT:

The PRIUS is equipped with a Supplemental Restraint System (SRS) and seat belt pretensioner.

Failure to carry out the service operations in the correct sequence could cause the SRS to unexpectedly deploy during servicing and lead to serious injury.

Furthermore, if a mistake is made when servicing the SRS, it is possible that the SRS may fail to operate properly. Before servicing (including removal or installation of parts, inspection or replacement), be sure to read the following section carefully.

(a) GENERAL NOTICE

- (1) As the malfunction symptoms of the SRS are difficult to confirm the Diagnostic Trouble Codes (DTCs) become the most important source of information when troubleshooting. When troubleshooting the SRS, always check the DTCs before disconnecting the battery (see page 05–1402).
- (2) Work must be started at least 90 seconds after the ignition switch is turned to the LOCK position and the negative (–) terminal cable is disconnected from the battery.
(The SRS is equipped with a back-up power source. If work is started within 90 seconds after turning the ignition switch to lock and disconnecting the negative (–) terminal cable from the battery, the SRS may deploy).
When the negative (–) terminal cable is disconnected from the battery, clock and audio system memory is erased. Before starting work, make a note of the settings of each memory system. When work is finished, reset the clock and audio systems as before.

CAUTION:

Never use the back-up power source (battery or other) to try to keep the system memory from being erased. The back-up power source may inadvertently power the SRS, and cause it to deploy.

- (3) In minor collisions where the SRS does not deploy, the horn button assembly, instrument panel passenger airbag assembly, front seat airbag assembly, curtain shield airbag assembly and seat belt pretensioner should be inspected before further use of the vehicle (see pages 60–22, 60–34, 60–43, 60–48 and 61–11).
- (4) Never use SRS parts from another vehicle. When replacing parts, use new parts.
- (5) Before repairs, remove the airbag sensor if impacts are likely to be applied to the sensor during repairs.
- (6) Never disassemble and repair the airbag sensor assembly, horn button assembly, instrument panel passenger airbag assembly, front seat airbag assembly, curtain shield airbag assembly or seat belt pretensioner.
- (7) Replace the center airbag sensor assembly, side airbag sensor assembly, horn button assembly or the instrument panel passenger airbag assembly, front seat airbag assembly or curtain shield airbag assembly if: 1) damage has occurred from being dropped, or 2) cracks, dents or other defects in the case, bracket or connector are present.
- (8) Do not directly expose the airbag sensor assembly, horn button assembly, instrument panel passenger airbag assembly, front seat airbag assembly, curtain shield airbag assembly or seat belt pretensioner to hot air or flames.
- (9) Use a voltmeter/ohmmeter with high impedance (10 k Ω /V minimum) for troubleshooting electrical circuits.
- (10) Information labels are attached to the SRS components. Follow the instructions on the labels.
- (11) After work on the SRS is completed, check the SRS warning lamp (see page 05–1397).

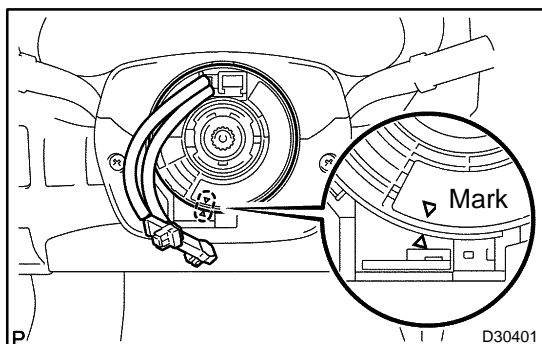

(b) SPIRAL CABLE (in Combination Switch)

- (1) The steering wheel must be fitted correctly to the steering column with the spiral cable in the neutral position, otherwise cable disconnection and other problems may occur. Refer to page 60-29 for information about correct installation of the steering wheel.

(c) HORN BUTTON ASSEMBLY (with Airbag)

- (1) When removing the horn button assembly or handling a new horn button, it should be placed with the pad surface facing up. See the illustration below. Placing the horn button with the pad surface facing down may lead to a serious accident if the airbag accidentally inflates. Also, do not place anything on top of the horn button.
- (2) Never measure the resistance of the airbag squib. This may cause the airbag to inflate, which could cause serious injury.
- (3) Grease or detergents of any kind should not be applied to the steering wheel pad.
- (4) Store the horn button assembly in an area where the ambient temperature is below 93°C (200°F), the humidity is not high and electrical noise is not nearby.
- (5) When using electric welding anywhere on the vehicle, disconnect the airbag sensor (ECU) connectors (4 pins). These connectors contain shorting springs. This feature reduces the possibility of the airbag or seat belt pretensioner deploying due to currents entering the squib wiring.
- (6) When disposing of the vehicle or the horn button assembly by itself, the airbag should be inflated using an SST before disposal (see page 60-22). Perform the operation in a safe place away from electrical noise.

Example:

CORRECT

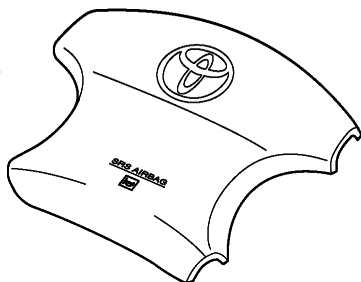

INCORRECT

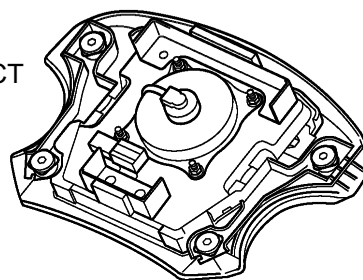

Y

D25096

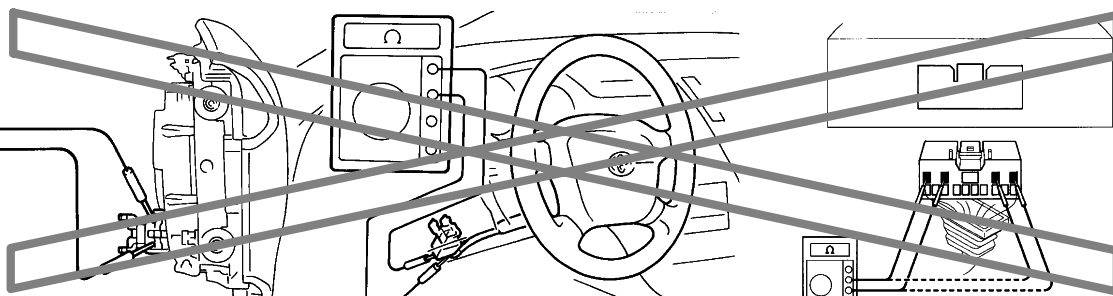
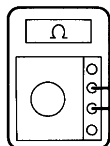
Example:

R05643 R06953 R06952

NEVER USE AN OHMMETER ON AN AIRBAG OR PRETENSIONER

Z13950

(d) INSTRUMENT PANEL PASSENGER AIRBAG ASSY

- (1) Always place a removed or new instrument panel passenger airbag assembly with the airbag inflation direction facing upward.
Placing the airbag assembly with the airbag inflation direction facing downward could cause a serious accident if the airbag inflates.
- (2) Never measure the resistance of the airbag squib. This may cause the airbag to inflate, which could cause serious injury.
- (3) Grease or detergents of any kind should not be applied to the instrument panel passenger airbag assembly.
- (4) Store the airbag assembly in an area where the ambient temperature is below 93°C (200°F), the humidity is not high and electrical noise is not nearby.
- (5) When using electric welding anywhere on the vehicle, disconnect the airbag ECU connectors (4 pins). These connectors contain shorting springs. This feature reduces the possibility of the airbag deploying due to currents entering the squib wiring.
- (6) When disposing of a vehicle or the airbag assembly unit by itself, the airbag should be deployed using SST before disposal (see page 60-34).
Activate in a safe place away from electrical noise.

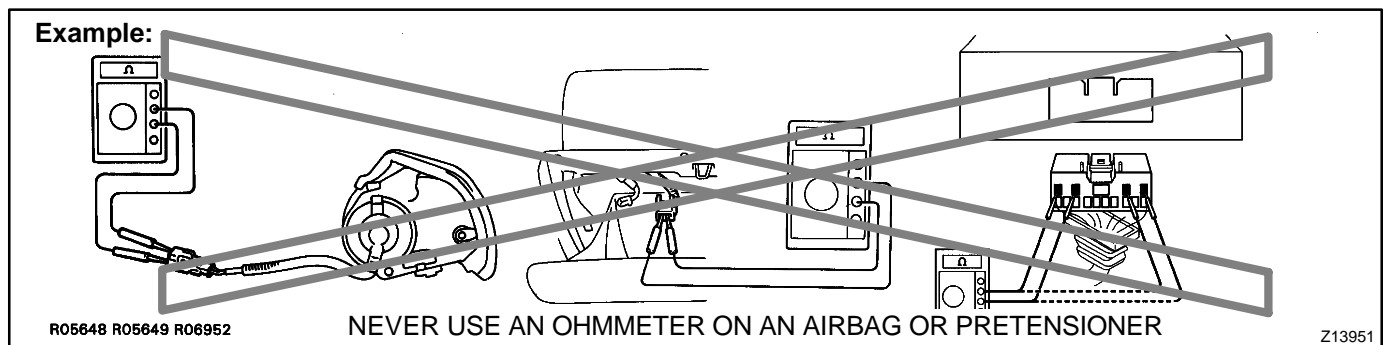
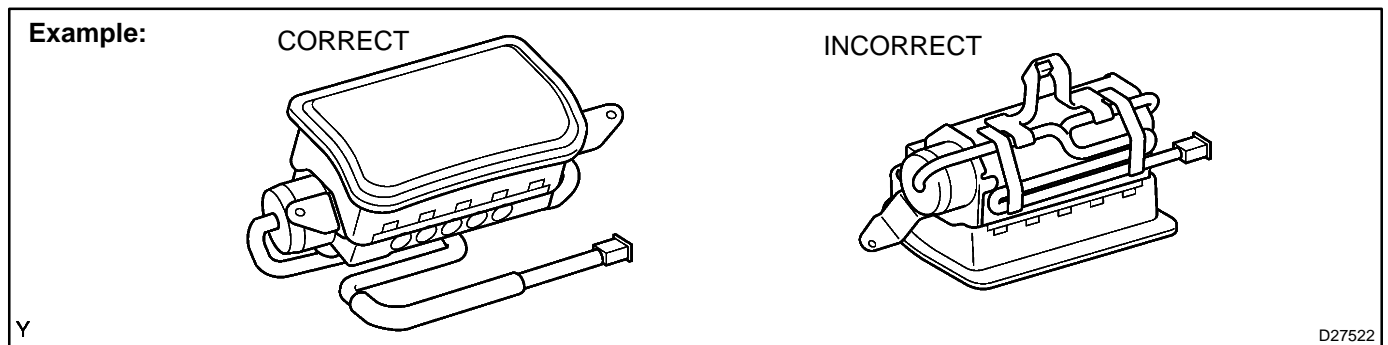

(e) CURTAIN SHIELD AIRBAG ASSEMBLY

- (1) Always place the removed or new curtain shield airbag assembly in a clear plastic bag, and keep it in a safe place.

NOTICE:

Plastic bag is not re-useable.

CAUTION:

Never disassemble the curtain shield airbag assembly.

- (2) Never measure the resistance of the airbag squib. This may cause the airbag to inflate, which could cause serious injury.
- (3) Grease or detergents of any kind should not be applied to the curtain shield airbag assembly.

- (4) Store the airbag assembly in an area where the ambient temperature is below 93°C (200°F), the humidity is not high and electrical noise is not nearby.
- (5) When using electric welding anywhere on the vehicle, disconnect the airbag sensor (ECU) connectors (2 pins). These connectors contain shorting springs. This feature reduces the possibility of the airbag deploying due to currents entering the squib wiring.
- (6) When disposing of a vehicle or the curtain shield airbag assembly unit by itself, the airbag should be deployed using SST before disposal (see page 60-43). Activate in a safe place away from electrical noise.

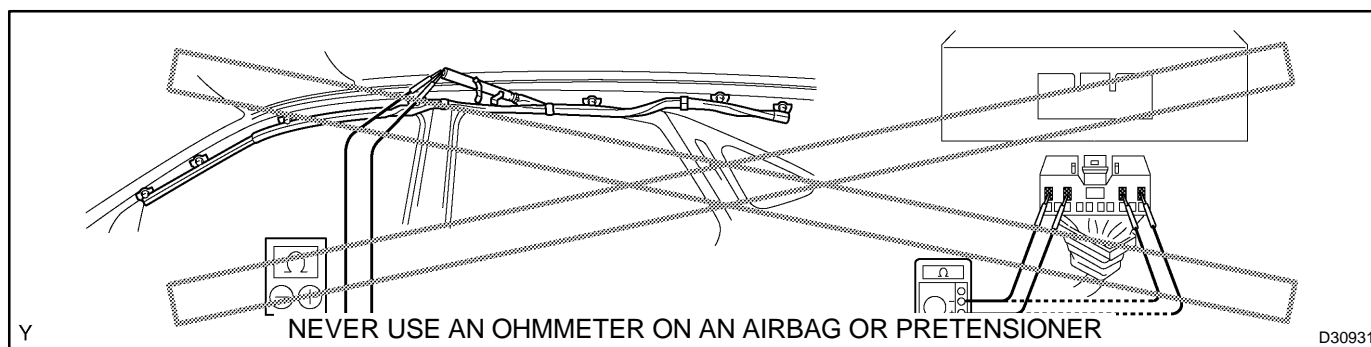
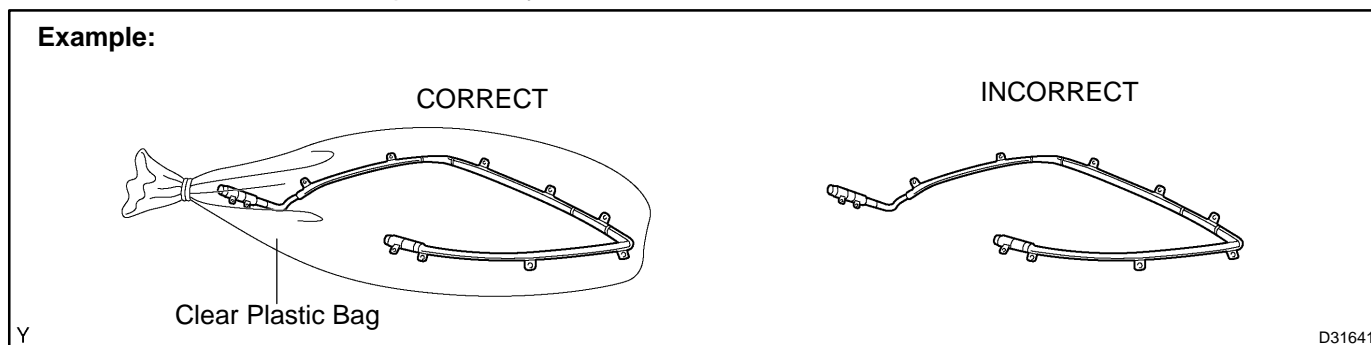

(f) **FRONT SEAT AIRBAG ASSEMBLY**

- (1) Always place a removed or new front seat airbag assembly with the airbag inflation direction facing up.
Placing the airbag assembly with the airbag inflation direction facing downward could cause a serious accident if the airbag deploys.
- (2) Never measure the resistance of the airbag squib. This may cause the airbag to inflate, which could cause serious injury.
- (3) Grease should not be applied to the front seat airbag assembly, and the airbag door should not be cleaned with detergents of any kind.
- (4) Store the airbag assembly in an area where the ambient temperature is below 93°C (200°F), the humidity is not high and electrical noise is not nearby.
- (5) When using electric welding anywhere on the vehicle, disconnect the airbag ECU connectors (2 pins). These connectors contain shorting springs. This feature reduces the possibility of the airbag deploying due to currents entering the squib wiring.
- (6) When disposing of a vehicle or the airbag assembly unit by itself, the airbag should be deployed using SST before disposal (see page 60-48). Activate in a safe place away from electrical noise.

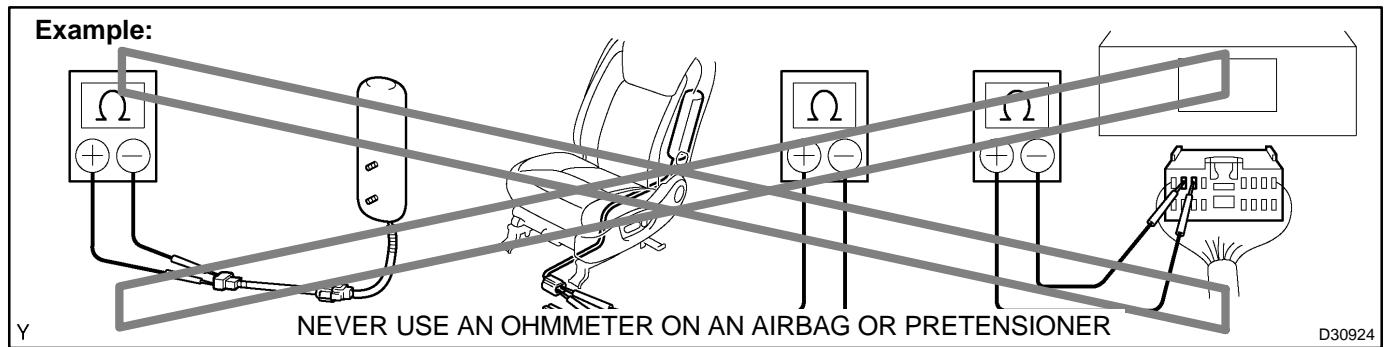

(g) SEAT BELT PRETENSIONER

- (1) Never measure the resistance of the seat belt pretensioner. This may cause the seat belt pretensioner to activate, which could cause serious injury.
- (2) Never disassemble the seat belt pretensioner.
- (3) Never install the seat belt pretensioner on another vehicle.
- (4) Store the seat belt pretensioner in an area where the ambient temperature is below 80°C (176°F), the humidity is not high and electrical noise is not nearby.
- (5) When using electric welding anywhere on the vehicle, disconnect the airbag sensor (ECU) connectors (2 pins). These connectors contain shorting springs. This feature reduces the possibility of the airbag deploying due to currents entering the squib wiring.
- (6) When disposing of a vehicle or the seat belt pretensioner unit by itself, the seat belt pretensioner should be activated before disposal (see page 61-11). Activate in a safe place away from electrical noise.
- (7) As the seat belt pretensioner is hot after being activated, allow some time for it to cool down sufficiently before disposal. Never apply water to try to cool down the seat belt pretensioner.
- (8) Grease, detergents, oil or water should not be applied to the front seat outer belt.

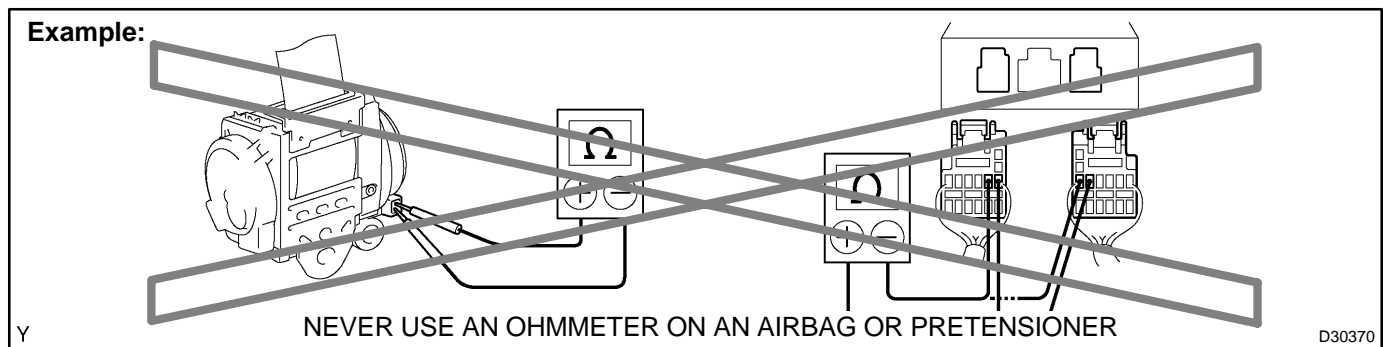

(h) AIRBAG SENSOR ASSEMBLY (ECU)

- (1) Never reuse an airbag sensor assembly that has been involved in a collision where the SRS has deployed.
- (2) The connectors to the airbag sensor assembly should be connected or disconnected with the sensor mounted on the floor. If the connectors are connected or disconnected while the airbag sensor assembly is not mounted to the floor, the SRS may activate.
- (3) Work must be started at least 90 seconds after the power switch's power mode is changed to OFF and the negative (-) terminal cable is disconnected from the battery, even if only loosening the set bolts of the airbag sensor assembly.

(i) WIRE HARNESS AND CONNECTOR

- (1) The SRS wire harness is integrated with the instrument panel wire harness assembly. All the connectors in the system are a standard yellow color. If the SRS wire harness becomes disconnected or the connector becomes broken, repair or replace it.

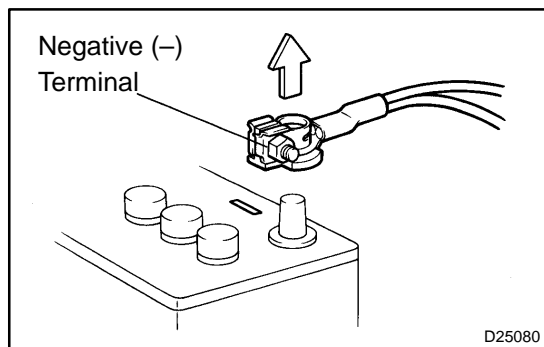

8. ELECTRONIC CONTROL

(a) REMOVAL AND INSTALLATION OF BATTERY TERMINAL

NOTICE:

After disconnecting the negative (-) terminal, it is necessary to perform the initialization of certain systems.

(see page 01-28)

- (1) Before performing electronic work, disconnect the battery negative (-) terminal cable beforehand to prevent component and wire damage caused by accidental short circuits.
- (2) When disconnecting the terminal cable, turn the ignition switch and lighting switch OFF and loosen the terminal nut completely. Perform these operations without twisting or prying the terminal. Remove the battery cable from the battery post.
- (3) Clock settings, radio settings, DTCs and other data are erased when the battery cable is removed. Before removing the battery cable, record any necessary data.

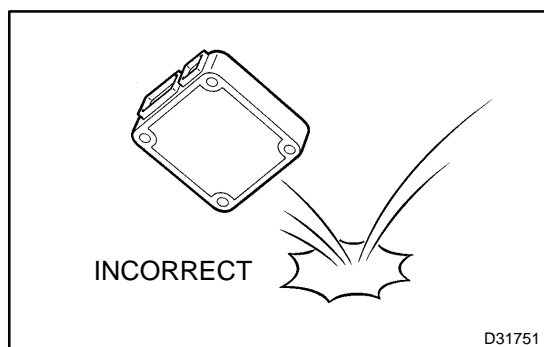

(b) HANDLING OF ELECTRONIC PARTS

- (1) Do not open the cover or case of the ECU unless absolutely necessary. If the IC terminals are touched, the IC may be rendered inoperative by static electricity.
- (2) To disconnect electronic connectors, pull the connector itself, not the wires.
- (3) Be careful not to drop electronic components, such as sensors or relays. If they are dropped on a hard surface, they should be replaced.
- (4) When cleaning the engine with steam, protect the electronic components, air filter and emission-related components from water.
- (5) Never use an impact wrench to remove or install temperature switches or temperature sensors.
- (6) When checking the resistance of a wire connector, insert the tester probe carefully to prevent terminals from bending.

9. REMOVAL AND INSTALLATION OF FUEL CONTROL PARTS

(a) PLACE FOR REMOVING AND INSTALLING OF FUEL SYSTEM PARTS

- (1) Work in a place with good air ventilation that does not have welders, grinders, drills, electric motors, stoves, or any other ignition sources.
- (2) Never work in a pit or near a pit as vaporized fuel will collect in those places.

(b) REMOVING AND INSTALLING OF FUEL SYSTEM PARTS

- (1) Prepare a fire extinguisher before starting operation.
- (2) To prevent static electricity, install a ground on the fuel changer, vehicle and fuel tank, and do not spray the area with water. The work surface will become slippery. Do not clean up spills with water as this will spread and gasoline and create a fire hazard.
- (3) Avoid using electric motors, working lights and other electric equipment that can cause sparks or high temperatures.
- (4) Avoid using iron hammers as they may create speaks.
- (5) Dispose of fuel-contaminated shop rags separately using a fire resistant container.

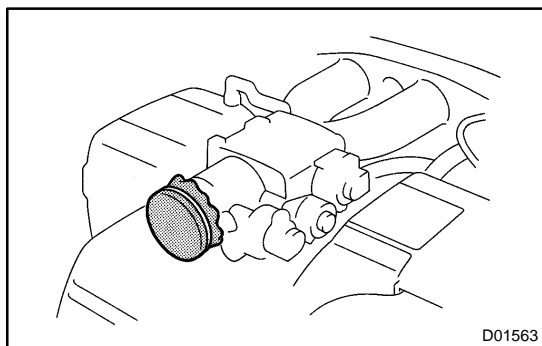

10. REMOVAL AND INSTALLATION OF ENGINE INTAKE PARTS

- (a) If any metal particle enters the inlet pass, this may damage the engine.
- (b) When removing and installing the inlet system parts, cover the openings of the removed parts and engine openings. Use clean shop rags, gummed tape, or other suitable materials.
- (c) When installing the inlet system parts, check that no metal particles have entered the engine or the installed part.

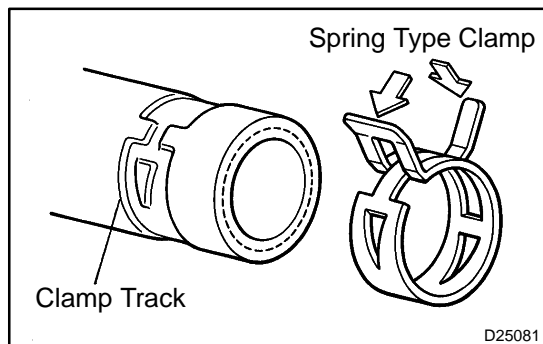

11. HANDLING OF HOSE CLAMPS

- (a) Before removing the hose, check the clamp position so that it can be reinstalled in the same position.
- (b) Replace deformed or dented clamps with a new one.
- (c) When reusing a hose, attach the clamp on the clamp track portion of the hose.
- (d) For a spring type clamp, you may want to spread the tabs slightly after installation by pushing in the direction of the arrow marks as shown in the illustration.

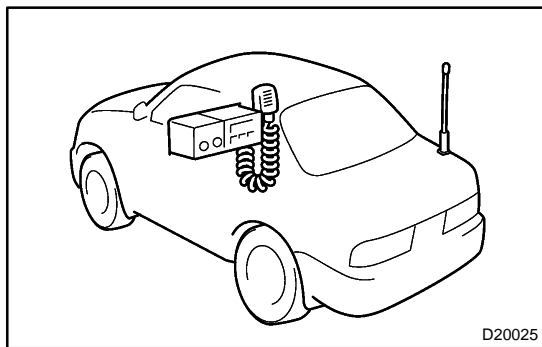

12. FOR VEHICLES EQUIPPED WITH MOBILE COMMUNICATION SYSTEMS

- (a) Install the antenna as far away from the ECU and sensors of the vehicle electronic systems as possible.
- (b) Install an antenna feeder at least 20 cm (7.87 in.) away from the ECU and sensors of the vehicle electronic systems. For details of the ECU and sensors locations, refer to the section on applicable components.
- (c) Keep the antenna and feeder separate from other wirings as much as possible. This will prevent signals from the communication equipment from affecting vehicle equipment and vice-versa.
- (d) Check that the antenna and feeder are correctly adjusted.
- (e) Do not install high-powered mobile communication systems.

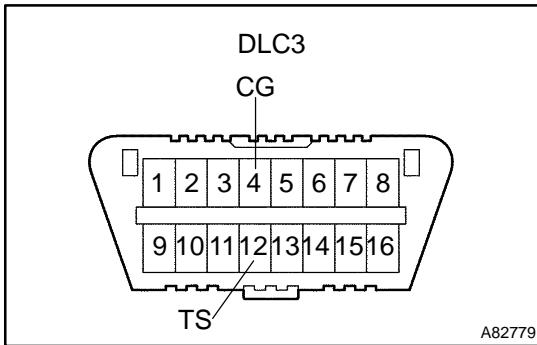

13. FOR VEHICLES EQUIPPED WITH VEHICLE STABILITY CONTROL (Enhanced VSC) SYSTEM

(a) NOTICES WHEN USING DRUM TESTER

- (1) Before beginning testing, disable the Vehicle Skid Control (Enhanced VSC) system. To disable the Enhanced VSC, change the power switch's power mode to OFF and connect SST to terminals TS and CG of the DLC3.

SST 09843-18040

NOTICE:

- Confirm that the VSC warning lamp is blinking.
- The Enhanced VSC system will be reset when the engine is restarted.
- For safety, secure the vehicle with restraint chains when using a wheel dynamometer.

(b) NOTICES OF RELATED OPERATIONS TO Enhanced VSC

- (1) Do not make unnecessary installations and removals as this may affect the adjustment of Enhanced VSC related parts.
- (2) Be sure to follow the Enhanced VSC system's instructions for work preparation and final confirmation of proper operation.

14. FOR VEHICLES EQUIPPED WITH CATALYTIC CONVERTER

CAUTION:

If a large amount of unburned gasoline or gasoline vapors flow into the converter, this may cause overheating and create a fire hazard. To prevent this, observe the following precautions.

- (a) Use only unleaded gasoline.
- (b) Avoid prolonged idling.
Avoid idling the engine for more than 20 minutes.
- (c) Avoid a spark jump test.
 - (1) Perform a spark jump test only when absolutely necessary. Perform this test as rapidly as possible.
 - (2) While testing, never rev the engine.
- (d) Avoid a prolonged engine compression measurement.
Engine compression measurements must be performed as rapidly as possible.
- (e) Do not run the engine when the fuel tank is nearly empty. This may cause the engine to misfire and create an extra load on the converter.

INITIALIZATION

NOTICE:

When disconnect the negative (–) battery terminal, initialize the following systems after the terminal is reconnected.

System Name	See Step No.
Power Window Control System	Step 1

1. RESET (INITIALIZE) POWER WINDOW REGULATOR MOTOR (DRIVER SIDE)

NOTICE:

- Resetting the power window regulator motor (initializing the pulse sensor) is necessary if: 1) the battery terminal cable is disconnected; 2) the power window regulator master switch assembly, wire harness, power window regulator switch, power window regulator assembly and power window regulator motor are replaced or removed/installed; or 3) the POWER fuse, FR Door fuse, GAUGE fuse and ECU-IG fuses are replaced. If resetting is not performed, the master switch assembly will not be able to operate the AUTO operation function, jam protection function and remote operation function.
- Whenever disconnecting the battery terminal cable, reset all the other systems besides the power window control system.
 - (a) Change the power mode to ON(IG) by pushing the power switch.
 - (b) Open the power window halfway by pressing the power window switch.
 - (c) Fully pull up on the switch until the power window is fully closed and continue to hold the switch for at least 1 second.
 - (d) Check that the AUTO UP/DOWN function operates normally.
If the AUTO UP/DOWN function operates normally, reset operations have been completed. If abnormal, follow steps (e) to (g) below.
 - (e) Disconnect the negative battery terminal cable for 10 seconds.
 - (f) Connect the battery terminal cable.
 - (g) Perform the above steps (a) to (d) again.

CUSTOMIZE PARAMETERS

HINT:

The following can be customized.

NOTICE:

After confirming whether the items of the customer's request are applicable or not for the customized items, perform the customize operation.

Be sure to record the current value before customizing.

In case of performing the troubleshooting, pay attention as there is a possibility that the function is OFF by customizing. (Example: In case of the symptom in which "The wireless operation does not function" is displayed, check that the wireless operation is not OFF by customizing, then perform the troubleshooting.)

AIR CONDITIONER

DISPLAY(ITEM)	DEFAULT	CONTENTS	SETTING
SET TEMP SHIFT (Set Temperature Shift)	NORMAL	To control with the shifted temperature against the display temperature.	+2C / +1C / NORMAL -1C / -2C
AIR INLET MODE (Air Inlet Mode)	AUTO	In case of turning the A/C ON when you desire to make the compartment cool down quickly, this is the function to change the mode automatically to RECIRCULATED mode.	MANUAL / AUTO
COMPRESSOR MODE (Compressor Mode)	AUTO	Function to turn the A/C ON automatically by pressing the AUTO button when the blower is ON and the A/C is OFF.	MANUAL / AUTO
COMPRS/DEF OPER (Compressor/Air inlet DEF operation)	LINK	Function to turn the A/C ON automatically linking with the FRONT DEF button when the A/C is OFF.	NORMAL / LINK
FOOT/DEF MODE (Foot/DEF auto mode)	ON	Function to turn the air flow from FOOT/DEF to ON automatically when AUTO MODE is ON.	OFF / ON
AUTO BLOW UP (Foot/DEF automatic blow up function)	ON	Function to switch the blower level automatically when the defroster is ON.	OFF / ON
FOOT AIR LEAK (Foot air leak)	ON	Function to cut off the airstream felt underfoot while the vehicle is moving	OFF / ON
AMBINT TMP SFT (Ambient Temperature Shift)	NORMAL	To control with the shifted ambient temperature against the display ambient temperature.	+3C / +2C / +1C NORMAL / -1C / -2C / -3C

ILLUMINATED ENTRY

DISPLAY (ITEM)	DEFAULT	CONTENTS	SETTING
LIGHTING TIME	15 s	Changes the lighting time after closing the doors (the light quickly fades out when the ignition switch is turned on).	7.5 s / 15 s / 30 s
I/L AUTO OFF	ON	Function to turn off the interior light automatically after specified time for prevent the battery loss when the interior light switch is "DOOR" position and the door is open.	ON / OFF
I/L ON/UNLOCK	ON	Function to light the interior light, etc. when the door is unlocked with a transmitter, door key or door lock control switch.	ON / OFF
I/L ON/ACC OFF	ON	Illuminates the interior light when the ignition switch is turned from the ACC to LOCK position.	ON / OFF

LIGHT CONTROL

DISPLAY (ITEM)	DEFAULT	CONTENTS	SETTING
SENSITIVITY	NORMAL	To adjust the sensitivity of the lighting illumination. Refer to the *1 illustration.	LIGHT2 / LIGHT1 / NORMAL / DARK1 / DARK2
DISP EX ON SEN	NORMAL	Changes the brightness when lowering lights such as the combination meter indicator lamp, A/C indicator lamp, and clock lamp. Refer to the illustration *2.	LIGHT2 / LIGHT1 / NORMAL / DARK1 / DARK2
DISP EX OFF SEN	NORMAL	Changes the brightness when lowering lights such as the combination meter indicator lamp, A/C indicator lamp, and clock. Refer to the illustration *3.	LIGHT2 / LIGHT1 / NORMAL / DARK1 / DARK2
DRL FUNCTION (●)	ON	ON/OFF of the DRL function.	ON / OFF

● : w/ Daytime Running Light for U.S.A.

Illustration of *1

Brightness of lowering the lights	Dark ←————→ Bright
Setting	DARK2 ——— DARK1 ——— NORMAL ——— LIGHT1 ——— LIGHT2

Illustration of *2

Brightness when canceling the lowering of the lights	Dark ←————→ Bright
Setting	DARK2 ——— DARK1 ——— NORMAL ——— LIGHT1 ——— LIGHT2

Illustration of *3

Lighting brightness	Dark ←————→ Bright
Setting	DARK2 ——— DARK1 ——— NORMAL ——— LIGHT1 ——— LIGHT2

BUZZER CANCEL SETTING

- (h) Check that the ODO display is on, and turn the power switch off and then on. If other display is on, change it to the ODO display.
- (i) Within 6 seconds, push and hold the ODO/TRIP switch for 10 seconds or more.
- (j) Following the table below, set the buzzer cancel setting.

Buzzer	Operation
Seat belt buzzers for driver's seat	Driver's seat buckle switch OFF → ON (Seat belt unfastened → fastened)
Seat belt buzzer for passenger seat	Passenger seat buckle switch OFF → ON (Seat belt unfastened → fastened)
A/T reverse buzzer	A/T R position → P position

HINT:

The ODO/TRIP display changes from "b-on" to "b-off", entering the cancel mode.

- (k) During the cancel mode, each time the ODO/TRIP switch is pushed, the setting is switched between*1 b-on and *2 b-off.

HINT:

*1 b-on: Cancel is invalid

*2 b-off: Cancel is valid

- (l) After the setting, the mode will be canceled by either not operating the switch for 10 seconds or more, or turning the power switch from on to off.

HINT:

The setting can be reset when reconnecting the battery connector or removing/installing the meter connector(Buzzer on).

SMART ENTRY SYSTEM

Display (Item)	Default	Contents	Setting
SMART WARN 1 (Warn key is taken from D-door with P position)	ON	Function that warns driver that key is taken out from driver's door when shift position is in P and power switch is not OFF	ON/OFF
SMART WARN 2 (Warn key is taken from D-door without P position)	ON	Function that warns driver that key is taken out from driver's door when shift position is not in P and power switch is not OFF	ON/OFF
SMART WARN 3 (Warn key is taken out by other passengers)	ON	Function that warns driver that key is taken out from any door except driver's door by passenger when power switch is not OFF	ON/OFF
SMART BUZ NUM (Setting number of warning buzzer sounds)	3 TIMES	Function that sets number of warning buzzer sounds when key is taken out of vehicle	OFF/ 3TIMES/5TIMES/7TIMES
SMART WARN 4 (Warn locking door when Engine is idling)	2s	Function that sets warning time for locking doors while engine is idling	OFF/1s/2s
SMART WARN 5 (Warn when key is left in vehicle)	2s	Function that sets warning time for locking doors while key is inside vehicle	OFF/1s/2s
SMART WARN 6 (Warn starting E/G when key is out of detection range)	ON	Function that warns driver that smart ignition control is being attempted to be activated while key is out of detection range	ON/OFF
KEY LOW-BATT WRN (Warn when key battery becomes weak)	ON	Function that warns driver that key's battery power is low	ON/OFF
SMART UNLOCK (Smart door unlock mode)	EACH	Function that makes smart unlock operation available.	AKK/EACH/D-door
TRANSMIT INTVAL (Transmission interval)	300ms	Function that sets smart signal transmission intervals when vehicle is stopped and key is outside vehicle	150ms/300ms/450ms/ 600ms
PARK WAIT TIME (Wait time to permit opening door after locking)	3.0s	Function that sets waiting time to permit opening door after door is locked with smart lock function	0.5s/1.5s/2.5s/5s
SMART BACK DOOR (Backdoor opening operation when vehicle is locked)	LONG	Function that enables back door to open when key is inside luggage compartment	LONG/TWICE/OFF

WIRELESS DOOR LOCK: w/ Smart Entry System

Display (item)	Default	Contents	Setting
OPEN DOOR WARN (Open door warning)	ON	If door is not completely closed and transmitter LOCK switch is pressed, this function makes buzzer sound for 10 seconds.	ON/OFF
WIRLS BUZZ OPER (Buzzer answer-back of wireless)	ON	Function that makes wireless buzzer sound for answer-back when transmitter lock/unlock switch is pressed.	ON/OFF
WIRELESS OPER (Wireless door lock control function)	ON	Function that turns wireless door lock function ON/OFF.	ON/OFF
ALARM FUNCTION (Panic function)	ON	Function that operates theft deterrent system when transmitter panic switch on transmitter is held for 0.8 seconds.	ON/OFF
UNLOCK/2OPER (2 times operation wireless unlock)	ON	Function that unlocks driver side door when unlock switch on transmitter is pressed once, and unlocks all doors when pressed twice. If on OFF setting, pressing unlock switch once makes all doors unlock.	ON/OFF
AUTO LOCK DELAY (Auto lock time)	30s	This function controls amount of time from unlocking doors to automatic re-locking function.	30s/60s
HAZARD ANS BACK (Hazard answer-back of wireless)	ON	When lock switch on transmitter is pressed, this function illuminates all hazard warning lamps once. when unlock switch is pressed, all hazard warning lamps illuminate twice.	ON/OFF

WIRELESS DOOR LOCK w/o Smart Entry System

Display (item)	Default	Contents	Setting
OPEN DOOR WARN (Open door warning)	ON	If door is not completely closed and transmitter LOCK switch is pressed, this function makes buzzer sound for 10 seconds.	ON/OFF
WIRELESS OPER (Wireless door lock control function)	ON	Function that turns wireless door lock function ON/OFF.	ON/OFF
ALARM FUNCTION (Panic function)	ON	Function that operates theft deterrent system when transmitter panic switch on transmitter is held for 0.8 seconds.	ON/OFF
UNLOCK/2OPER (2 times operation wireless unlock)	ON	Function that unlocks driver side door when unlock switch on transmitter is pressed once, and unlocks all doors when pressed twice. If on OFF setting, pressing unlock switch once makes all doors unlock.	ON/OFF
AUTO LOCK DELAY (Auto lock time)	30s	This function controls amount of time from unlocking doors to automatic re-locking function.	30s/60s
HAZARD ANS BACK (Hazard answer-back of wireless)	ON	When lock switch on transmitter is pressed, this function illuminates all hazard warning lamps once. when unlock switch is pressed, all hazard warning lamps illuminate twice.	ON/OFF

Theft deterrent system

DISPLAY (ITEM)	DEFAULT	CONTENTS	SETTING
PASSIVE MODE (Passive arming mode)	OFF	PASSIVE MODE is a function that switches theft deterrent system from arming preparation state to armed state 30 seconds after key is removed from key slot and all doors is closed, even if doors are not locked by wireless or door key lock operation In PASSIVE MODE, theft deterrent system will judge that a theft is taking place and switch to alarm sounding state if one of the following operations are not performed within 14 seconds (see ENTRY DELAY below) after door is opened: Unlock any door by key or wireless operation Reconnect battery Insert key into key slot and turn the power switch ON (IG).	ON/OFF
WARN BY HORN (Warning by horn)	ON	Function that allows vehicle horn and theft deterrent horn to be able to be used as a warning device	ON/OFF
ENTRY DELAY (Entry delay time)	14 s	Function that changes entry delay time (time before warning starts)	0 s/14 s/30 s
WARN BY GLS SEN (Warning by glass broken sensor)	ON	Function that turns glass broken sensor ON/OFF	ON/OFF

VEHICLE LIFT AND SUPPORT LOCATIONS

1. NOTICE ABOUT VEHICLE CONDITION WHEN JACKING UP

- (a) The vehicle must be unloaded before jacking up the vehicle. Never jack up/lift up a heavily loaded vehicle.
- (b) When removing heavy equipment such as the engine and transmission, the center of gravity of the vehicle may shift. To stabilize the vehicle: place a balance weight in a location where it will not roll or shift; or use a mission jack to hold the jacking support.

2. NOTICE FOR USING 4 POST LIFT

- (a) Follow the safety procedures outlined in its instruction manual.
- (b) Use precautionary measures to prevent the free beam from damaging tires or wheels.
- (c) Use wheel chocks to secure the vehicle.

3. NOTICE FOR USING JACK AND SAFETY STAND

- (a) Work in a flat area using wheel chocks at all times.

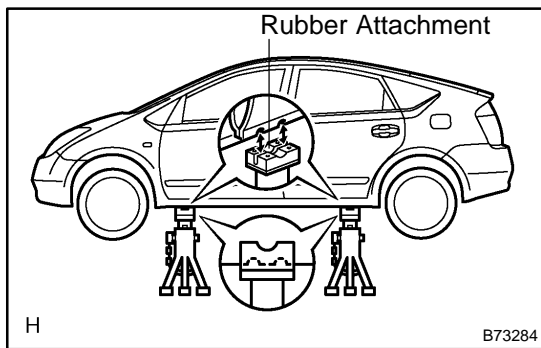

- (b) Use a safety stand with a rubber attachment, as shown in the illustration.
- (c) Apply the jack and rigid rack to the specified location on the vehicle.
- (d) When jacking up the front wheels, release the parking brake and place wheel chocks only behind the rear wheels. When jacking up the rear wheels, place wheel chocks only in front of the front wheels.
- (e) The jack should not be used without the rigid rack.

- (f) When jacking up only the front wheels or only the rear wheels, place wheel chocks on both sides of the wheels touching the ground.
- (g) When lowering the vehicle with its front wheels jacked up, release the parking brake and place wheel chocks only in front of the rear wheels. When lowering a vehicle with its rear wheels jacked up, place wheel chocks only behind the front wheels.

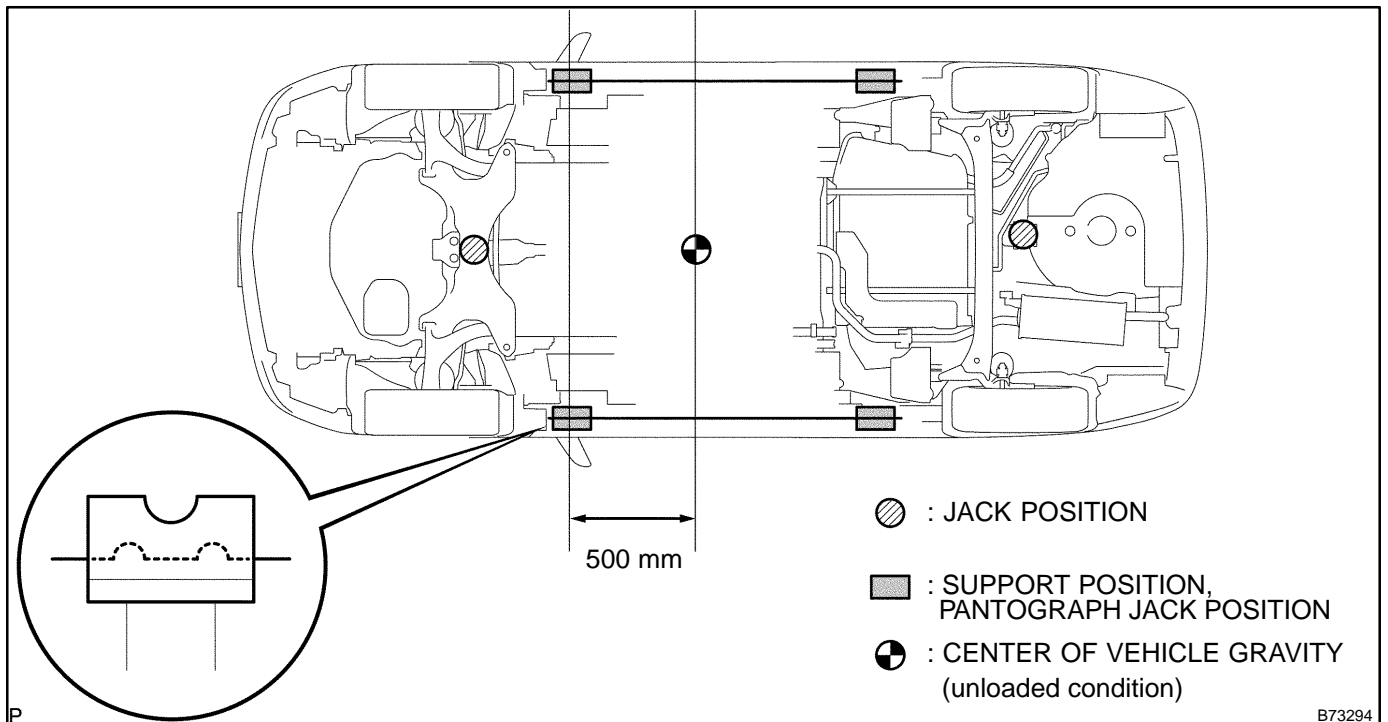

4. NOTICE FOR USING SWING ARM TYPE LIFT

- (a) Follow the safety procedures outlined in its instruction manual.
- (b) Use swing arms equipped with rubber attachments, as shown in the illustration.
- (c) When using the lift, its center should be as close to the vehicle's center of gravity as possible.
- (d) Set the vehicle on the lift as level as possible. Then match the groove of the lift to the rigid rack support location.
- (e) Be sure to lock the swing arms before lifting and during work (if equipped with arm locks).
- (f) Lift the vehicle up off the ground. Stand at a safe distance and shake the vehicle to check its stability.

5. NOTICE FOR USING PLATE TYPE LIFT

- (a) Follow the safety procedures outlined in its instruction manual.
- (b) Use plate lift attachments (rubber lifting blocks) on top of the plate surface.
- (c) Refer to the table below to determine how to properly set the vehicle.

Right and left set position	Place the vehicle over the center of the lift.
Front and rear set position	Place the attachments at the ends of the rubber plate surface, under the vehicle lift pad (A and C in the illustration). Raise the plate slightly and reposition the vehicle so the top of the attachment (B in the illustration) is aligned with the front side notch in the vehicle rocker flange.

- (d) Lift the vehicle up off the ground, and shake it to make sure that it is stable.

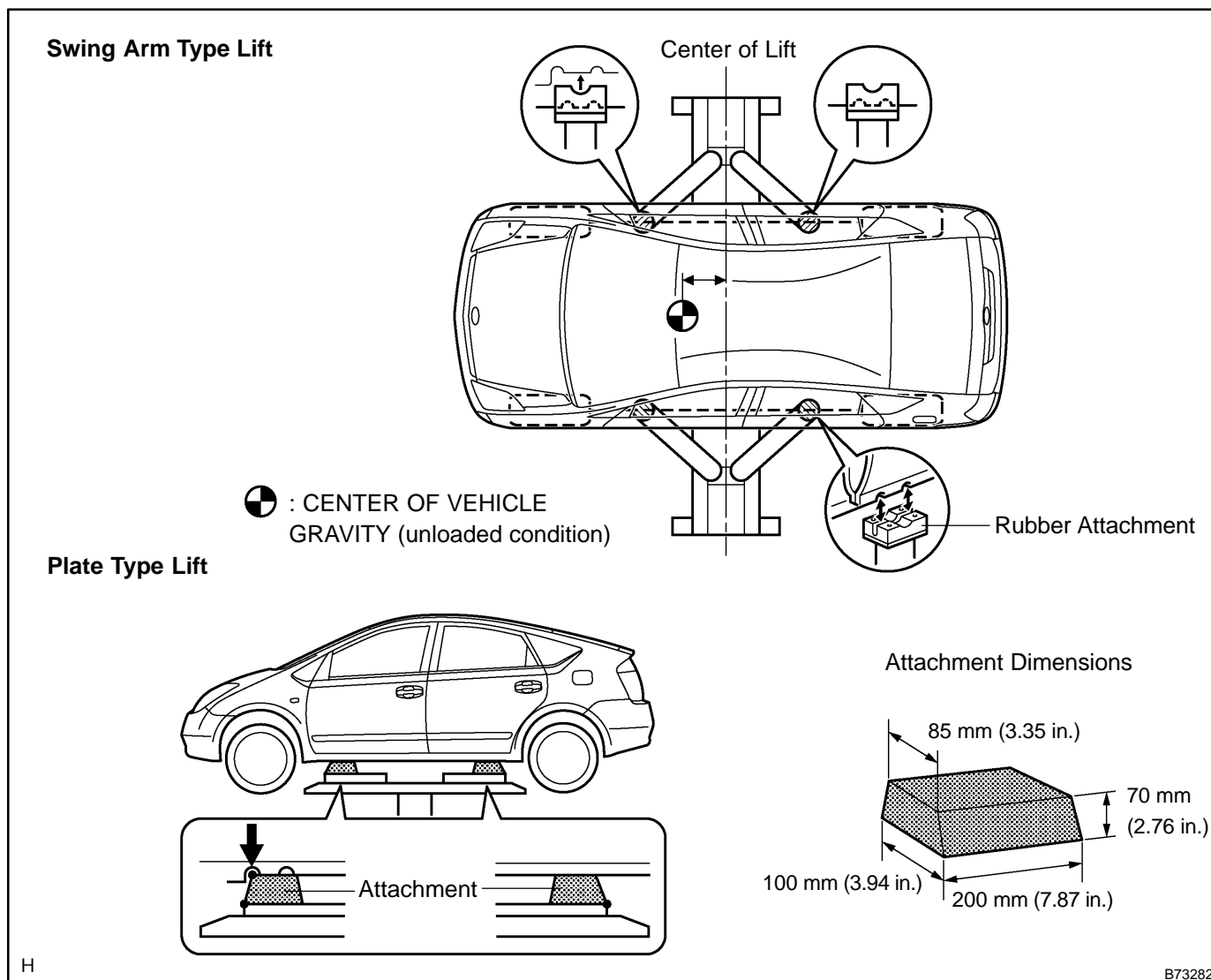

HOW TO TROUBLESHOOT ECU CONTROLLED SYSTEMS

GENERAL INFORMATION

010S3-01

A large number of ECU controlled systems are used in the PRIUS. In general, ECU controlled systems are considered to be very intricate, requiring a high level of technical knowledge to troubleshoot. However, most problem checking procedures only involve inspecting the ECU controlled system's circuits one by one. An adequate understanding of the system and a basic knowledge of electricity is enough to perform effective troubleshooting, accurate diagnoses and necessary repairs. Detailed information and troubleshooting procedures on major ECU controlled systems in this vehicle are outlined below:

System	Page
1. SFI System	05-1
2. Hybrid Control System	05-385
3. Hybrid Battery System	05-863
4. Electronically Controlled Brake System	05-943
5. Shift Control System (Parking Lock Control)	05-1139
6. Electronic Power Steering System	05-1203
7. Air Conditioning System	05-1247
8. Supplemental Restraint System	05-1384
9. Lighting System	05-1659
10. Audio System	05-1751
11. Navigation System	05-1841
12. Combination Meter	05-1975
13. Power Window Control System	05-2020
14. Power Door Lock Control System	05-2070
15. Smart Entry System	05-2135
16. Wireless Door Lock Control System (w/ Smart Entry System)	05-2223
17. Wireless Door Lock Control System (w/o Smart Entry System)	05-2267
18. Push Button Start System	05-2420
19. Key Reminder Warning System	05-2307
20. Engine Immobilizer System (w/ Smart Entry System)	05-2325
21. Engine Immobilizer System (w/o Smart Entry System)	05-2375
22. Theft Deterrent System	05-2494
23. Multiplex Communication System	05-2537
24. CAN Communication System	05-2596
25. Cruise Control System	05-2679

FOR USING OBD II SCAN TOOL OR HAND-HELD TESTER

- Before using the scan tool or tester, the scan tool's instruction book or tester's operator manual should be read thoroughly.
- If the scan tool or tester cannot communicate with the ECU controlled systems when you have connected the cable of the tester to the DLC3 with the power switch and tester turned ON, there is a problem on the vehicle side or tester side.
 - (1) If communication is normal when the tester is connected to another vehicle, inspect the diagnosis data link line (Bus \oplus line) or ECU power circuit of the vehicle.
 - (2) If communication is still impossible when the tester is connected to another vehicle, the problem is probably in the tester itself. Perform the Self Test procedures outlined in the Tester Operator's Manual.

HOW TO PROCEED WITH TROUBLESHOOTING

HINT:

Carry out troubleshooting in accordance with the procedures below. Only a basic procedure is shown. Details in the Diagnostic Section show the most effective methods for each circuit. Confirm the troubleshooting procedures for the relevant circuit before beginning troubleshooting.

1 VEHICLE BROUGHT TO WORKSHOP



2 CUSTOMER PROBLEM ANALYSIS

- (a) Ask the customer about the conditions and environment when the problem occurred.



3 SYMPTOM CONFIRMATION AND DTC (AND FREEZE FRAME DATA) CHECK

- (a) Check the auxiliary battery voltage.
Standard: 11 to 14 V (Engine stopped)
- (b) Visually check the wire harness, connectors and fuses for open and short circuits.
- (c) Warm up the engine to the normal operating temperature.
- (d) Confirm the problem symptoms and conditions, and check for DTCs according to the related chart.

OK

Go to step 5

NG

4 DTC CHART

- (a) Check the results obtained in step 3, then confirm the inspection procedures for the system or part using the DTC chart.



Go to step 6

5 PROBLEM SYMPTOMS CHART

- (a) Check the results obtained in step 3. Confirm the inspection procedures for the system or part using the problem symptoms table.



6 CIRCUIT INSPECTION OR PARTS INSPECTION

- (a) Confirm the circuit in the system or the part that should be checked using the problem symptoms table or the results obtained in step 4.



7	REPAIR
----------	---------------

- (a) Repair the affected system or part according to the instructions in step 6.



8	CONFIRMATION TEST
----------	--------------------------

- (a) After completing repairs, confirm that the problem has been solved. If the problem does not recur, perform a confirmation test under the same conditions and in the same environment as when it occurred the first time.



END

CUSTOMER PROBLEM ANALYSIS

HINT:

In troubleshooting, the problem symptoms must be confirmed accurately. Preconceptions should be discarded in order to give an accurate judgement. To clearly understand what the problem symptoms are, it is extremely important to ask the customer about the problem and the conditions at the time it occurred.

As much information as possible should be gathered for reference. Past problems that seem unrelated may also help in some cases. In the Diagnostic section, a customer problem analysis table is provided for each system.

5 items are important points in the problem analysis:

Important Points with Customer Problem Analysis

- What ——— Vehicle model, system name
- When ——— Date, time, occurrence frequency
- Where ——— Road conditions
- Under what conditions? ——— Running conditions, driving conditions, weather conditions
- How did it happen? ——— Problem symptoms

(Sample) Supplemental Restraint System check sheet

CUSTOMER PROBLEM ANALYSIS CHECK			
Supplemental Restraint System Check Sheet		Inspector's Name	
Customer's Name	VIN		
	Production Date		/ /
	License Plate No.		
Date Vehicle Brought In	/ /	Odometer Reading	km miles
Date Problem First Occurred	/ /		
Weather	<input type="checkbox"/> Fine <input type="checkbox"/> Cloudy <input type="checkbox"/> Rainy <input type="checkbox"/> Snowy <input type="checkbox"/> Other		
Temperature	Approx.		
Vehicle Operation	<input type="checkbox"/> Starting <input type="checkbox"/> Idling <input type="checkbox"/> Driving [<input type="checkbox"/> Constant speed <input type="checkbox"/> Acceleration <input type="checkbox"/> Deceleration] <input type="checkbox"/> Other		

SYMPTOM CONFIRMATION AND DIAGNOSTIC TROUBLE CODE

HINT:

The diagnostic system in the PRIUS has various functions.

The first function is the Diagnostic Trouble Code (DTC) check. A DTC is a code stored in the ECU memory whenever a malfunction in the signal circuits to the ECU occurs. In a DTC check, a previous malfunction's DTC can be checked by a technician during troubleshooting.

Another function is the Input Signal Check, which checks if the signals from various switches are sent to the ECU correctly.

By using these functions, the problem areas can be narrowed down and troubleshooting is more effective. Diagnostic functions are incorporated in the following systems in the PRIUS:

System	Diagnostic Trouble Code Check	Input Signal Check (Sensor Check)	Diagnostic Test Mode (Active Test)
SFI System	☑ (with Check Mode)	☑	☑
Hybrid Control System	☑		☑
Hybrid Battery System	☑		☑
Electronically Controlled Brake System	☑	☑	☑
Shift Control System (Parking Lock Control)	☑		
Electronic Power Steering System	☑	☑	
Air Conditioning System	☑		☑
Supplemental Restraint System	☑	☑	
Audio System	☑	☑	
Navigation System		☑	
Power Window Control System	☑		☑
Power Door Lock Control System	☑		☑
Smart Entry System			☑
Wireless Door Lock Control System	☑		☑
Engine Immobilizer System	☑		☑
Push Button Start System	☑		☑
Multiplex Communication System	☑		
CAN Communication System	☑		☑
Cruise Control System	☑		☑

In the DTC check, it is very important to determine whether the problem indicated by the DTC is: 1) still occurring, or 2) occurred in the past but has since returned to normal. In addition, the DTC should be compared to the problem symptom to see if they are related. For this reason, DTCs should be checked before and after confirmation of symptoms (i.e., whether or not problem symptoms exist) to determine current system conditions, as shown in the table below.

Never skip the DTC check. Failure to check DTCs may, depending on the case, result in unnecessary troubleshooting for systems operating normally or lead to repairs not pertinent to the problem. Follow the procedures listed in the flow chart in the correct order.

A flow chart showing how to proceed with troubleshooting using the DTC check is shown below. Directions from the flow chart will indicate how to proceed either to DTC troubleshooting or to the troubleshooting of the problem symptoms.

1	DTC CHECK
----------	------------------



2 MAKE A NOTE OF DTCS DISPLAYED AND THEN CLEAR THE MEMORY



3 SYMPTOM CONFIRMATION

☑	Symptoms exist
☑	No symptoms exist

a → **Go to step 5**

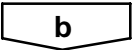

4 SIMULATION TEST USING SYMPTOM SIMULATION METHODS



5 DTC CHECK

☑	DTC displayed
☑	No DTC displayed

a → **TROUBLESHOOTING OF PROBLEM INDICATED BY DTC**

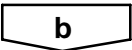

6 SYMPTOM CONFIRMATION

☑	No symptoms exist
☑	Symptoms exist

If a DTC was displayed in the initial DTC check, the problem may have occurred in a wire harness or connector in that circuit in the past. Check the wire harness and connectors (see page 01-47).

a → **SYSTEM NORMAL**

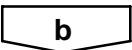

TROUBLESHOOTING OF EACH PROBLEM SYMPTOM

The problem is still occurring in a place other than the diagnostic circuit (the DTC displayed first is either for a past problem or a secondary problem).

SYMPTOM SIMULATION

HINT:

The most difficult case in troubleshooting is when no problem symptoms occur. In such cases, a thorough customer problem analysis must be carried out. A simulation of the same or similar conditions and environment in which the problem occurred in the customer's vehicle should be carried out. No matter how much skill or experience a technician has, troubleshooting without confirming the problem symptoms will lead to important repairs being overlooked and mistakes or delays.

For example:

With a problem that only occurs when the engine is cold or occurs as a result of vibration caused by the road during driving, the problem can never be determined if the symptoms are being checked on a stationary vehicle or a vehicle with a warmed-up engine.

Vibration, heat or water penetration (moisture) is difficult to reproduce. The symptom simulation tests below are effective substitutes for the conditions and can be applied on a stationary vehicle.

Important points in the symptom simulation test:

In the symptom simulation test, the problem symptoms as well as the problem area or parts must be confirmed. First, narrow down the possible problem circuits according to the symptoms. Then, connect the tester and carry out the symptom simulation test, judging whether the circuit being tested is defective or normal. Also, confirm the problem symptoms at the same time. Refer to the problem symptoms table for each system to narrow down the possible causes.

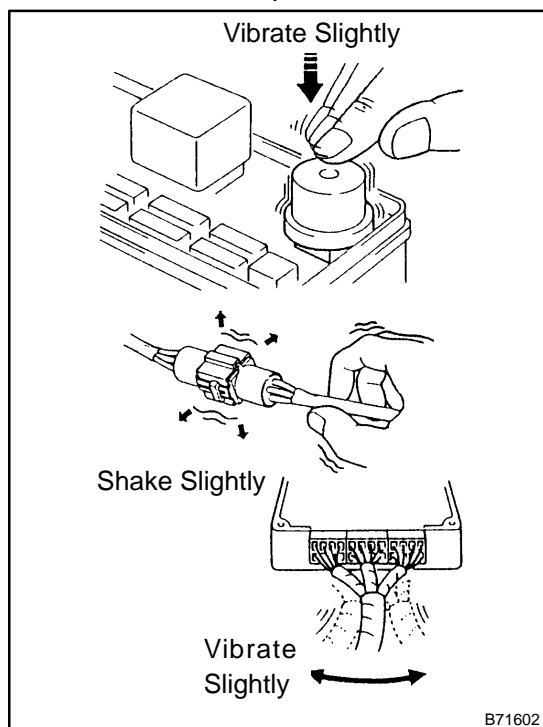

1. VIBRATION METHOD: When vibration seems to be the major cause.

(a) PART AND SENSOR

- (1) Apply slight vibration with a finger to the part of the sensor considered to be the cause of the problem and check whether or not the malfunction occurs.

HINT:

Applying strong vibration to relays may open relays.

(b) CONNECTORS

- (1) Slightly shake the connector vertically and horizontally.

(c) WIRE HARNESS

- (1) Slightly shake the wire harness vertically and horizontally.

The connector joint and fulcrum of the vibration are the major areas that should be checked thoroughly.

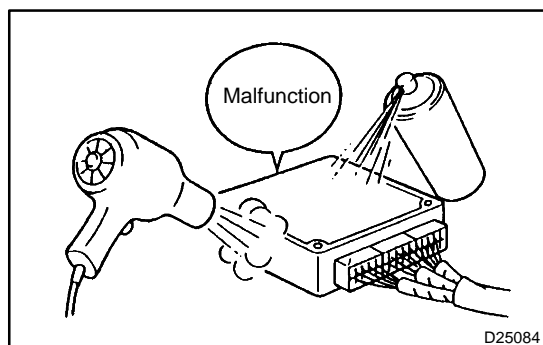

2. HEAT METHOD: If the problem seems to occur when the area in question is heated.

- (a) Heat the component that is the possible cause of the malfunction with a hair dryer or similar device. Check if the malfunction occurs.

NOTICE:

Do not heat the component to more than 60 °C (140 °F). Exceeding this temperature may cause damage.

Do not apply heat directly to the parts in the ECU.

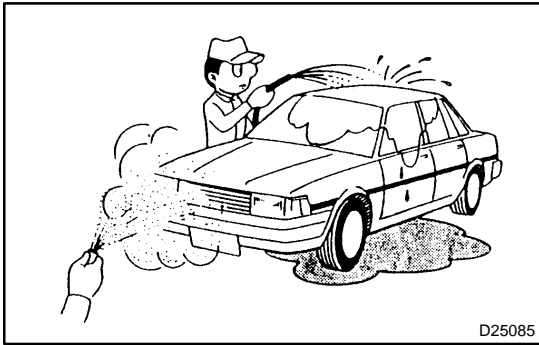

- 3. WATER SPRINKLING METHOD:** When the malfunction seems to occur on a rainy day or in high humidity.
- (a) Sprinkle water onto the vehicle and check if the malfunction occurs.

NOTICE:

Never sprinkle water directly into the engine compartment. Indirectly change the temperature and humidity by applying water spray onto the front of the radiator.

Never apply water directly onto electronic components.

HINT:

If the vehicle has or had a water leakage problem, the leakage may have damaged the ECU or connections. Look for evidence of corrosion or shorts. Proceed with caution during water tests.

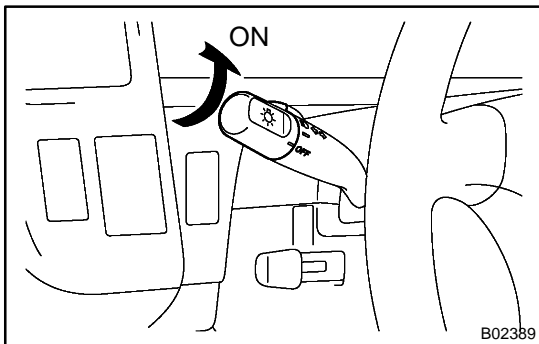

- 4. HIGH ELECTRICAL LOAD METHOD:** When a malfunction seems to occur when electrical load is excessive.
- (a) Turn on the heater blower, headlights, rear window defogger and all other electrical loads. Check if the malfunction reoccurs.

DIAGNOSTIC TROUBLE CODE CHART

Use Diagnostic Trouble Codes (DTCs) (from the DTC checks) in the table below to determine the trouble area and proper inspection procedure. The Supplemental Restraint System (SRS) DTC chart is shown below as an example.

- DTC No.
Indicates the DTC.
- Page or Instructions
Indicates the page where the inspection procedures for each circuit is to be found, or gives instructions for checking and repairs.

- Trouble Area
Indicates the suspected areas of the problem.

- Detection Item
Indicates the system or details of the problem.

DIAGNOSTIC TROUBLE CODE CHART
If a malfunction code is displayed during the DTC check, check the circuit for that code listed in the table below (Proceed to the page given for that circuit).

DTC No. (See page)	Detection Item	Trouble Area	SRS Warning Lamp
B0100/13 (05-119)	● Short in D squib circuit	<ul style="list-style-type: none"> ● Steering wheel pad (squib) ● Spiral cable ● Airbag sensor assembly ● Wire harness 	ON
B0101/14 (05-124)	● Open in D squib circuit	<ul style="list-style-type: none"> ● Steering wheel pad (squib) ● Spiral cable ● Airbag sensor assembly ● Wire harness 	ON
B0102/11 (05-128)	● Short in D squib circuit (to ground)	<ul style="list-style-type: none"> ● Steering wheel pad (squib) ● Spiral cable ● Airbag sensor assembly ● Wire harness 	ON
B0103/12 (05-132)	● Short in D squib circuit (to B+)	<ul style="list-style-type: none"> ● Steering wheel pad (squib) ● Spiral cable ● Airbag sensor assembly ● Wire harness 	ON
B0105/53 (05-136)	● Short in P squib circuit	<ul style="list-style-type: none"> ● Front passenger airbag assembly (squib) ● Airbag sensor assembly ● Wire harness 	ON
B0106/54	● Open in P squib circuit	<ul style="list-style-type: none"> ● Front passenger airbag assembly (squib) ● Airbag sensor assembly ● Wire harness 	
	● Short in P squib circuit (to Ground)	<ul style="list-style-type: none"> ● Front passenger airbag assembly (squib) ● Airbag sensor assembly ● Wire harness 	

PROBLEM SYMPTOMS TABLE

The suspected circuits or parts for each problem symptom are shown in the table below. Use this table to troubleshoot when, during a DTC check, a "Normal" code is displayed but the problem is still occurring. Numbers in the table show the inspection order in which the circuits or parts should be checked.

HINT:

In some cases, the problem is not detected by the diagnostic system even though a problem symptom is present. It is possible that the problem is occurring outside the detection range of the diagnostic system, or that the problem is occurring in a completely different system.

● Page
Indicates the page where the flow chart for each circuit is located.

● Circuit Inspection, Inspection Order
Indicates the circuit which needs to be checked for each problem symptom. Check in the order indicated by the numbers.

● Problem Symptom

● Circuit or Part Name
Indicates the circuit or part which needs to be checked.

PROBLEM SYMPTOMS TABLE HINT: Inspect the "Fuse" and "Relay" before confirming the suspected area in the charts below (See page 68-1).		
Symptom	Suspected Area	See Page
Black screen	1. Power source circuit (multi-display assy) 2. Multi-display	05-1267 67-7
Screen cannot be dimmer in night time	1. SRS warning light circuit (multi-display assy) 2. Multi-display assy	05-1277 67-7
A navigation system cannot be operated	1. Steering pad switch circuit 2. AVC-LAN circuit (radio receiver assy-multi-display assy) 3. Radio receiver assy 4. Multi-display assy	05-1183 05-1303 67-5 67-7

CIRCUIT INSPECTION

How to read and use each page is shown below.

● **Circuit Description**

The major role, operation of the circuit and its component parts are explained.

● **Diagnostic Trouble Code No. and Detection Item**

● Indicates the diagnostic trouble codes, diagnostic trouble code settings and suspected problem areas.

● **Inspection Procedures**

Use the inspection procedures to determine if the circuit is normal or abnormal. If it is abnormal, use it to determine whether the problem is located in the sensors, actuators, wire harness or ECU.

05-178 DIAGNOSTICS - SEI SYSTEM (1ZZ-FE) **DTC P0500/42 VEHICLE SPEED SENSOR MALFUNCTION**

CIRCUIT DESCRIPTION

The vehicle speed sensor outputs a 4-pulse signal for every revolution of the rotor shaft, which is rotated by the transmission output shaft via the driven gear. After this signal is converted into a more precise rectangular waveform by the waveform shaping circuit inside the combination meter, it is then transmitted to the Engine ECU. The Engine ECU determines the vehicle speed based on the frequency of these pulse signals.

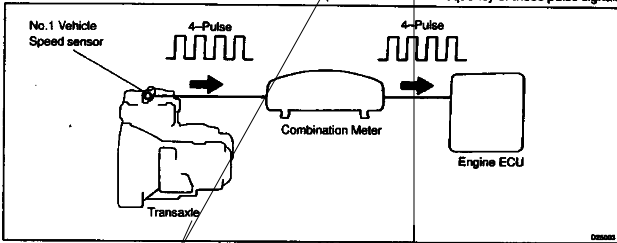

DTC No.	DTC Detecting Condition	Trouble Area
P0500/42	During vehicle is being driven, no vehicle speed sensor signal to engine ECU (2 trip detection logic)	<ul style="list-style-type: none"> • Combination meter • Open or short in No. 1 vehicle speed sensor circuit • No. 1 vehicle speed sensor • Engine ECU

WIRING DIAGRAM

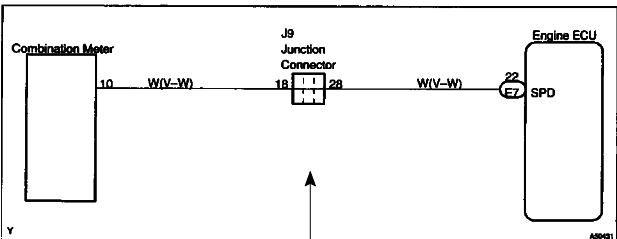

● **Wiring Diagram**

This shows a wiring diagram of the circuit. Use this diagram together with ELECTRICAL WIRING DIAGRAM to thoroughly understand the circuit.

Wire colors are indicated by an alphabetical code. B = Black, L = Blue, R = Red, BR = Brown, LG = Light Green, V = Violet, G = Green, O = Orange, W = White, GR = Gray, P = Pink, Y = Yellow, SB = Sky Blue. The first letter indicates the basic wire color and the second letter indicates the color of the stripe.

DIAGNOSTICS - SEI SYSTEM (1ZZ-FE) 05-179

INSPECTION PROCEDURE

1 READ VALUE OF VEHICLE SPEED VALUE(SPEEDOMETER OPERATION)

- (a) Select data monitor on the hand-held tester.
- (b) Perform a test drive of the vehicle.
- (c) Read the vehicle speed on the hand-held tester.

RESULT: The same as the speed displayed on the speed meter.

NG → REPLACE COMBINATION METER ASSY

OK

2 INSPECT ECU

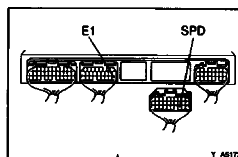

(a) Check the output waveform.
HINT: Using the oscilloscope function of hand-held tester, it is possible to check the function between the engine ECU and the knock control sensor. The waveform shown in the illustration is an example without noise and chattering.

- (1) Connect the hand-held tester between the terminals SPD of the engine ECU E7 connector and E1 of the engine ECU E8 connector.
- (2) Select the oscilloscope function on the hand-held tester. (Refer to the hand-held tester's instruction book for operating instructions.)

RESULT: Voltage is intermittently generated.

ITEM	CONTENTS
TERMINAL	SPD↔E1
EQUIPMENT SET	5V/DIV, 20ms/DIV
CONDITION	Running at 20 km/h

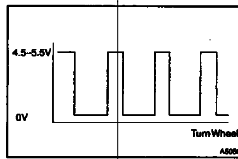

HINT:
 • The multitude gets shorter as the engine speed becomes faster.

OK → CHECK AND REPLACE ECU

NG

● Indicates the condition of the connector of the ECU during the check.

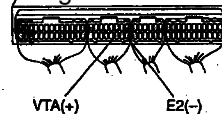

Connector being checked is connected.

Connections of tester are indicated by (+), (-) after terminal name.

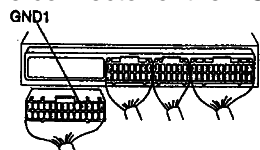

Connector being checked is disconnected.

For measuring between connector (terminal) and body ground, the terminal is indicated but body ground is not

ELECTRONIC CIRCUIT INSPECTION PROCEDURE

1. BASIC INSPECTION

(a) RESISTANCE MEASURING CONDITION OF ELECTRONIC PARTS

- (1) Unless stated, all resistance is measured at an ambient temperature of 20 C (68 F). Resistances measured may be outside the specifications if measured at high temperatures, i.e. immediately after the vehicle has been running. Measurements should be made after the engine has cooled down.

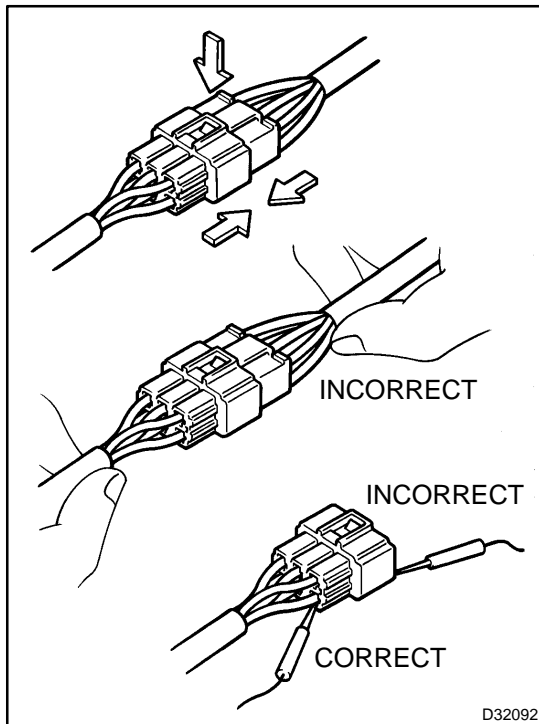

(b) HANDLING CONNECTORS

- (1) When disconnecting a connector, first squeeze the mating halves tightly together to release the lock, then press the lock claw and separate the connector.
- (2) When disconnecting a connector, do not pull on the harnesses. Grasp the connector directly and separate it.
- (3) Before connecting the connector, check that there are no deformed, damaged, loose or missing terminals.
- (4) When connecting a connector, press firmly until you hear the lock close with a "click" sound.
- (5) If checking the connector with a TOYOTA electrical tester, check it from the backside (harness side) of the connector using a mini test lead.

NOTICE:

- **As a waterproof connector cannot be checked from the backside, check by connecting a sub-harness.**
- **Do not damage the terminals by moving the inserted tester needle.**

(c) CHECKING CONNECTORS

- (1) Checking when the connector is connected: Squeeze the connector together to confirm that it is fully inserted and locked.
- (2) Checking when the connector is disconnected: Check by pulling the wire harness lightly from the backside of the connector. Look for unlatched terminals, missing terminals, loose crimps or broken conductor wires. Check visually for corrosion, metallic or foreign objects and water; and bent, rusted, overheated, contaminated, and deformed terminals.

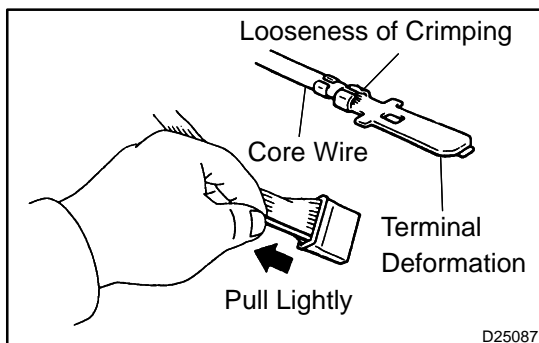

NOTICE:

When testing a gold-plated female terminal, always use a gold-plated male terminal.

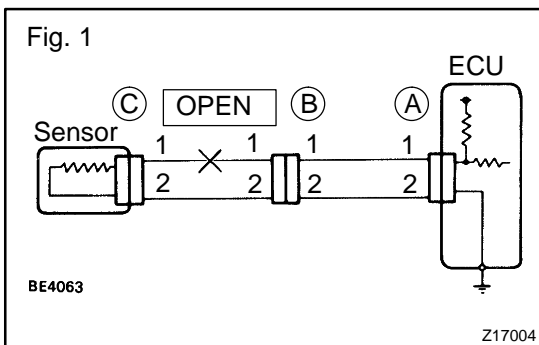
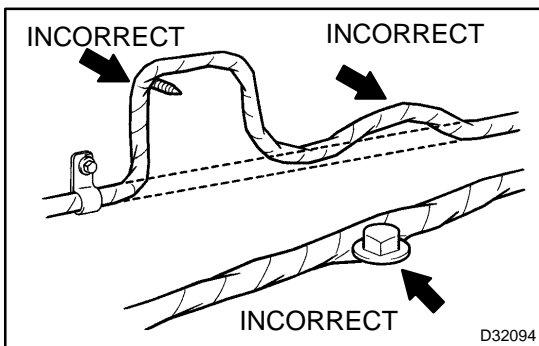
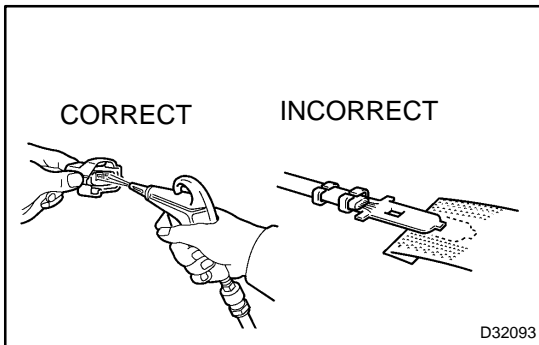
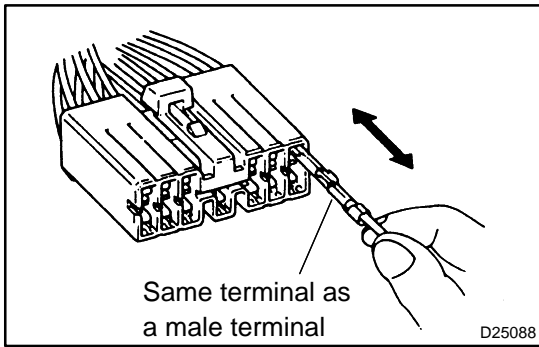

- (3) Checking the contact pressure of the terminal:
Prepare a spare male terminal. Insert it into a female terminal, and check for good tension when inserting and after full engagement.

(d) REPAIR METHOD OF CONNECTOR TERMINAL

- (1) If there is any dirt on the terminal, clean the contact point using an air gun or shop rag. Never polish the contact point using sandpaper as the platings may come off.
- (2) If there is abnormal contact pressure, replace the female terminal. If the male terminal is gold-plated (gold color), use a gold-plated female terminal; if it is silver-plated (silver color), use a silver-plated female terminal.
- (3) Damaged, deformed, or corroded terminals should be replaced. If the terminal will not lock into the housing, the housing may have to be replaced.

(e) HANDLING OF WIRE HARNESS

- (1) If removing a wire harness, check the wiring and clamping before proceeding so that it can be restored in the same way.
- (2) Never twist, pull or slacken the wire harness more than necessary.
- (3) Never make the wire harness come into contact with a high temperature part, rotating, moving, vibrating or sharp-edged parts. Avoid panel edges, screw tips and similar sharp items.
- (4) When installing parts, never pinch the wire harness.
- (5) Never cut or break the cover of the wire harness. If it is cut or broken, replace it or securely repair it with vinyl tape.

2. CHECK OPEN CIRCUIT

- (a) For an open circuit in the wire harness in Fig. 1, perform a resistance check (step b) or a voltage check (step c).

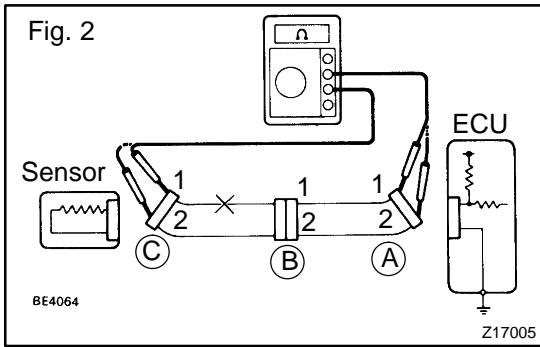

- (b) Check the resistance.
 (1) Disconnect connectors A and C and measure the resistance between them.

Resistance: Below 1 Ω

HINT:

Measure the resistance while lightly shaking the wire harness vertically and horizontally.

Fig. 2:

Tester Connection	Specified Condition
Connector A terminal 1 – Connector C terminal 1	10 kΩ or higher
Connector A terminal 2 – Connector C terminal 2	Below 1 kΩ

If your results match the examples above, an open circuit exists between terminal 1 of connector A and terminal 1 of connector C.

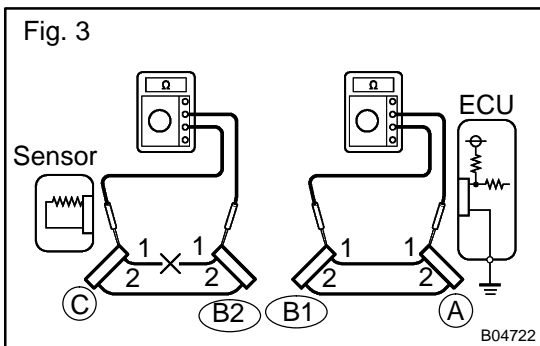

- (2) Disconnect connector B and measure the resistance between the connectors.

Fig. 3:

Tester Connection	Specified Condition
Connector A terminal 1 – Connector B1 terminal 1	Below 1 kΩ
Connector B2 terminal 1 – Connector C terminal 1	10 kΩ or higher

If your results match the examples above, an open circuit exists between terminal 1 of connector B2 and terminal 1 of connector C.

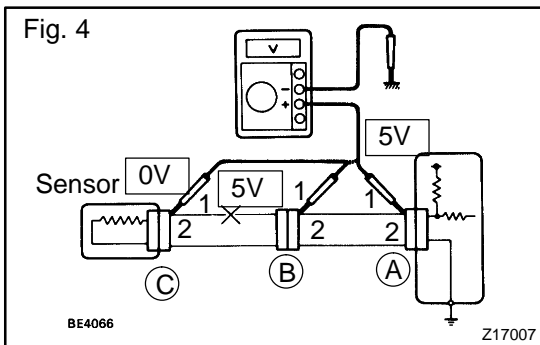

- (c) Check the voltage.
 (1) In a circuit in which voltage is applied to the ECU connector terminal, an open circuit can be checked by conducting a voltage check.

Fig. 4:

With each connector still connected, measure the voltage between the body ground these terminals (in this order): 1) terminal 1 of connector A at the ECU 5V output terminal, 2) terminal 1 of connector B, and 3) terminal 1 of connector C.

(2) Example results:

Tester Connection	Specified Condition
Connector A terminal 1 – Body ground	5 V
Connector B terminal 1 – Body ground	5 V
Connector C terminal 1 – Body ground	0 V

If your results match the examples above, an open circuit exists in the wire harness between terminal 1 of B and terminal 1 of C.

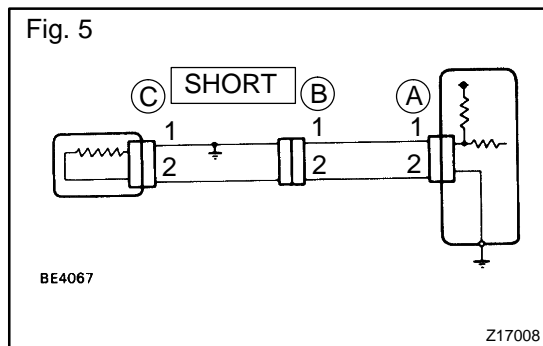

3. CHECK SHORT CIRCUIT

(a) If the wire harness is ground shorted (Fig. 5), locate the section by conducting a resistance check with the body ground (below).

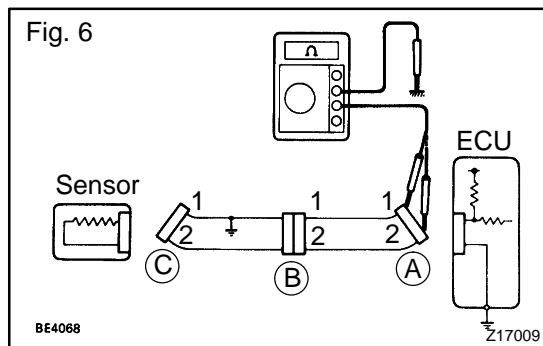

(b) Check the resistance with the body ground.

- (1) Disconnect connectors A and C and measure the resistance between terminals 1 and 2 of connector A and the body ground.

Resistance: 10 kΩ or higher

HINT:

Measure the resistance while lightly shaking the wire harness vertically and horizontally.

Fig. 6:

Tester Connection	Specified Condition
Connector A terminal 1 – Body ground	Below 1 kΩ
Connector A terminal 2 – Connector C terminal 2	10 kΩ or higher

If your results match the examples above, a short circuit exists between terminal 1 of connector A and terminal 1 of connector C.

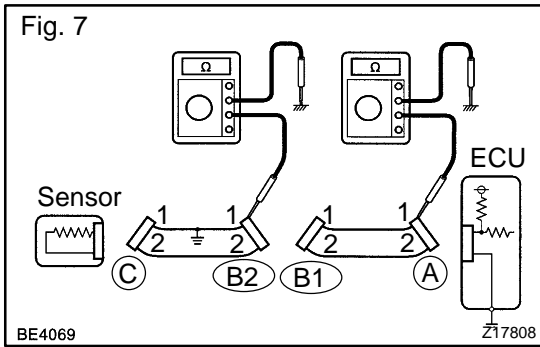

- (2) Disconnect connector B and measure the resistance between terminal 1 of connector A and the body ground, and terminal 1 of connector B2 and the body ground.

Fig. 7:

Tester Connection	Specified Condition
Connector A terminal 1 – Body ground	10 kΩ or higher
Connector B2 terminal 1 – Body ground	Below 1 kΩ

If your results match the examples above, a short circuit exists between terminal 1 of connector B2 and terminal 1 of connector C.

4. CHECK AND REPLACE ECU

NOTICE:

- The connector should not be disconnected from the ECU. Perform the inspection from the backside of the connector on the wire harness side.
 - When no measuring condition is specified, perform the inspection with the engine stopped and the ignition switch ON.
 - Check that the connectors are fully seated. Check for loose, corroded or broken wires.
- (a) First check the ECU ground circuit. If it is faulty, repair it. If it is normal, the ECU could be faulty. Replace the ECU with a normal functioning one and check if the symptoms occur. If the trouble symptoms stop, replace the ECU.

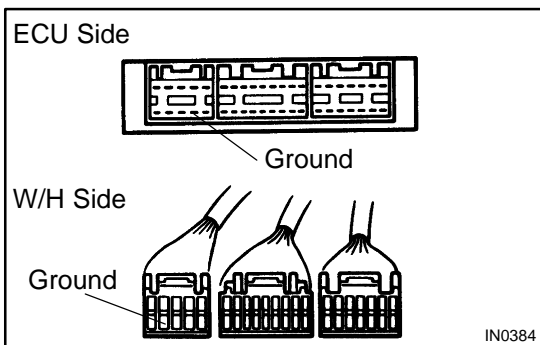
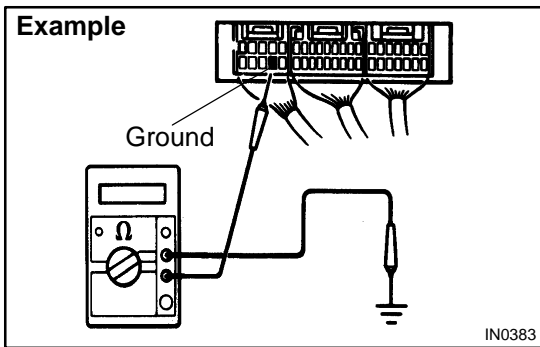

- (1) Measure the resistance between the ECU ground terminal and body ground.

Resistance: Below 1 Ω

- (2) Disconnect the ECU connector. Check the ground terminals (on the ECU side and wire harness side) for evidence of bending, corrosion or foreign material. Lastly check the contact pressure of the female terminals.

TERMS

ABBREVIATIONS USED IN MANUAL

010S6-01

Abbreviations	Meaning
ABS	Anti-Lock Brake System
A/C	Air Conditioner
AC	Alternating Current
ACC	Accessory
ACIS	Acoustic Control Induction System
ACSD	Automatic Cold Start Device
A.D.D.	Automatic Disconnecting Differential
A/F	Air-Fuel Ratio
AHC	Active Height Control Suspension
ALR	Automatic Locking Retractor
ALT	Alternator
AMP	Amplifier
ANT	Antenna
Approx.	Approximately
ASSY	Assembly
A/T, ATM	Automatic Transmission
ATF	Automatic Transmission Fluid
AUTO	Automatic
AUX	Auxiliary
AVG	Average
AVS	Adaptive Variable Suspension
B+	Battery Voltage
BA	Brake Assist
BACS	Boost Altitude Compensation System
BAT	Battery
BDC	Bottom Dead Center
B/L	Bi-Level
B/S	Bore-Stroke Ratio
BTDC	Before Top Dead Center
BVSV	Bimetallic Vacuum Switching Valve
CAN	Controller Area Network
CB	Circuit Breaker
CCo	Catalytic Converter For Oxidation
CD	Compact Disc
CF	Cornering Force
CG	Center Of Gravity
CH	Channel
CKD	Complete Knock Down
COMB.	Combination
CPE	Coupe
CPS	Combustion Pressure Sensor
CPU	Central Processing Unit
CRS	Child Restraint System
CTR	Center
C/V	Check Valve
CV	Control Valve
CW	Curb Weight
DC	Direct Current

Abbreviations	Meaning
DEF	Defogger
DFL	Deflector
DIFF.	Differential
DIFF. LOCK	Differential Lock
D/INJ	Direct Injection
DLC	Data Link Connector
DLI	Distributorless Ignition
DOHC	Double Overhead Camshaft
DP	Dash Pot
DS	Dead Soak
DSP	Digital Signal Processor
DTC	Diagnostic Trouble Code
DVD	Digital Versatile Disc
EBD	Electric Brake Force Distribution
ECAM	Engine Control And Measurement System
ECD	Electronic Controlled Diesel
ECDY	Eddy Current Dynamometer
ECT	Electronic Control Transmission
ECU	Electronic Control Unit
ED	Electro-Deposited Coating
EDU	Electronic Driving Unit
EDIC	Electric Diesel Injection Control
EFI	Electronic Fuel Injection
E/G	Engine
EGR	Exhaust Gas Recirculation
EGR-VM	EGR-Vacuum Modulator
ELR	Emergency Locking Retractor
EMPS	Electric Motor Power Steering
ENG	Engine
ESA	Electronic Spark Advance
ETCS-i	Electronic Throttle Control System-intelligent
EVAP	Evaporative Emission Control
EVP	Evaporator
E-VRV	Electric Vacuum Regulating Valve
EX	Exhaust
FE	Fuel Economy
FF	Front-Engine Front-Wheel-Drive
F/G	Fuel Gauge
FIPG	Formed In Place Gasket
FL	Fusible Link
F/P	Fuel Pump
FPU	Fuel Pressure Up
Fr	Front
F/W	Flywheel
FW/D	Flywheel Damper
FWD	Front-Wheel-Drive
GAS	Gasoline
GND	Ground
GPS	Global Positioning System
HAC	High Altitude Compensator
H/B	Hatchback

Abbreviations	Meaning
H-FUSE	High Current Fuse
HI	High
HID	High Intensity Discharge (Head Lamp)
HSG	Housing
HT	Hard Top
HWS	Heated Windshield System
IC	Integrated Circuit
IDI	Indirect Diesel Injection
IFS	Independent Front Suspension
IG	Ignition
I/A	Integrated Ignition Assembly
IN	Intake (Manifold, Valve)
INT	Intermittent
I/P	Instrument Panel
IRS	Independent Rear Suspension
ISC	Idle Speed Control
J/B	Junction Block
J/C	Junction Connector
KD	Kick-Down
LAN	Local Area Network
LB	Liftback
LCD	Liquid Crystal Display
LED	Light Emitting Diode
LH	Left-Hand
LHD	Left-Hand Drive
L/H/W	Length, Height, Width
LLC	Long-Life Coolant
LNG	Liquified Natural Gas
LO	Low
LPG	Liquified Petroleum Gas
LSD	Limited Slip Differential
LSP & PV	Load Sensing Proportioning And Bypass Valve
LSPV	Load Sensing Proportioning Valve
MAP	Manifold Absolute Pressure
MAX.	Maximum
MIC	Microphone
MIL	Malfunction Indicator Lamp
MIN.	Minimum
MG1	Motor Generator No.1
MG2	Motor Generator No.2
MP	Multipurpose
MPI	Multipoint Electronic Injection
MPX	Multiplex Communication System
M/T, MTM	Manual Transmission (Transaxle)
MT	Mount
MTG	Mounting
N	Neutral
NA	Natural Aspiration
No.	Number
O2S	Oxygen Sensor
O/D	Overdrive

INTRODUCTION – 2004 Prius – Preliminary Release (RM1075U)

Abbreviations	Meaning
OEM	Original Equipment Manufacturing
OHC	Overhead Camshaft
OHV	Overhead Valve
OPT	Option
ORVR	On-board Refilling Vapor Recovery
O/S	Oversize
P & BV	Proportioning And Bypass Valve
PCS	Power Control System
PCV	Positive Crankcase Ventilation
PKB	Parking Brake
PPS	Progressive Power Steering
PTC	Positive Temperature Coefficient
PS	Power Steering
PTO	Power Take-Off
P/W	Power Window
R & P	Rack And Pinion
RAM	Random Access Memory
R/B	Relay Block
RBS	Recirculating Ball Type Steering
R/F	Reinforcement
RFS	Rigid Front Suspension
RH	Right-Hand
RHD	Right-Hand Drive
RLY	Relay
ROM	Read Only Memory
Rr	Rear
RRS	Rigid Rear Suspension
RWD	Rear-Wheel Drive
SDN	Sedan
SEN	Sensor
SICS	Starting Injection Control System
SOC	State Of Charge
SOHC	Single Overhead Camshaft
SPEC	Specification
SPI	Single Point Injection
SRS	Supplemental Restraint System
SSM	Special Service Materials
SST	Special Service Tools
STD	Standard
STJ	Cold-Start Fuel Injection
SW	Switch
SYS	System
T/A	Transaxle
TACH	Tachometer
TBI	Throttle Body Electronic Fuel Injection
TC	Turbocharger
TCCS	TOYOTA Computer-Controlled System
TCV	Timing Control Valve
TDC	Top Dead Center
TEMP.	Temperature
TEMS	TOYOTA Electronic Modulated Suspension

Abbreviations	Meaning
TFT	TOYOTA Free-Tronic
TIS	Total Information System For Vehicle Development
T/M	Transmission
TMC	TOYOTA Motor Corporation
TMMK	TOYOTA Motor Manufacturing Kentucky, Inc.
TRAC	Traction Control System
TURBO	Turbocharge
TWC	Three-Way Catalyst
U/D	Underdrive
U/S	Undersize
VCV	Vacuum Control Valve
VENT	Ventilator
VIN	Vehicle Identification Number
VPS	Variable Power Steering
VSC	Vehicle Stability Control
VSV	Vacuum Switching Valve
VTV	Vacuum Transmitting Valve
VVT-i	Variable Valve Timing-intelligent
w/	With
WGN	Wagon
W/H	Wire Harness
w/o	Without
WU-TWC	Warm Up Three-way Catalytic Converter
WU-OC	Warm Up Oxidation Catalytic Converter
1st	First
2nd	Second
2WD	Two Wheel Drive Vehicle (4 x 2)
3rd	Third
4th	Fourth
4WD	Four Wheel Drive Vehicle (4 x 4)
4WS	Four Wheel Steering System
5th	Fifth

GLOSSARY OF SAE AND TOYOTA TERMS

This glossary lists all SAE–J1930 terms and abbreviations used in this manual in compliance with SAE recommendations, as well as their TOYOTA equivalents.

SAE ABBREVIATIONS	SAE TERMS	TOYOTA TERMS ()—ABBREVIATIONS
A/C	Air Conditioning	Air Conditioner
ACL	Air Cleaner	Air Cleaner, A/CL
AIR	Secondary Air Injection	Air Injection (AI)
AP	Accelerator Pedal	–
B+	Battery Positive Voltage	+B, Battery Voltage
BARO	Barometric Pressure	HAC
CAC	Charge Air Cooler	Intercooler
CARB	Carburetor	Carburetor
CFI	Continuous Fuel Injection	–
CKP	Crankshaft Position	Crank Angle
CL	Closed Loop	Closed Loop
CMP	Camshaft Position	Cam Angle
CPP	Clutch Pedal Position	–
CTOX	Continuous Trap Oxidizer	–
CTP	Closed Throttle Position	LL ON, Idle ON
DFI	Direct Fuel Injection	Direct Injection (DI/INJ)
DI	Distributor Ignition	–
DLC1 DLC2 DLC3	Data Link Connector 1 Data Link Connector 2 Data Link Connector 3	1: Check Connector 2: Total Diagnosis Communication Link (TDCL) 3: OBD II Diagnostic Connector
DTC	Diagnostic Trouble Code	Diagnostic Trouble Code
DTM	Diagnostic Test Mode	–
ECL	Engine Coolant Level	–
ECM	Engine Control Module	Engine ECU (Electronic Control Unit)
ECT	Engine Coolant Temperature	Coolant Temperature, Water Temperature (THW)
EEPROM	Electrically Erasable Programmable Read Only Memory	Electrically Erasable Programmable Read Only Memory (EEPROM), Erasable Programmable Read Only Memory (EPROM)
EFE	Early Fuel Evaporation	Cold Mixture Heater (CMH), Heat Control Valve (HCV)
EGR	Exhaust Gas Recirculation	Exhaust Gas Recirculation (EGR)
EI	Electronic Ignition	Distributorless Ignition (DLI)
EM	Engine Modification	Engine Modification (EM)
EPROM	Erasable Programmable Read Only Memory	Programmable Read Only Memory (PROM)
EVAP	Evaporative Emission	Evaporative Emission Control (EVAP)
FC	Fan Control	–
FEEPROM	Flash Electrically Erasable Programmable Read Only Memory	–
FEPROM	Flash Erasable Programmable Read Only Memory	–
FF	Flexible Fuel	–
FP	Fuel Pump	Fuel Pump
GEN	Generator	Alternator
GND	Ground	Ground (GND)

HO2S	Heated Oxygen Sensor	Heated Oxygen Sensor (HO ₂ S)
IAC	Idle Air Control	Idle Speed Control (ISC)
IAT	Intake Air Temperature	Intake or Inlet Air Temperature
ICM	Ignition Control Module	–
IFI	Indirect Fuel Injection	Indirect Injection (IDL)
IFS	Inertia Fuel-Shutoff	–
ISC	Idle Speed Control	–
KS	Knock Sensor	Knock Sensor
MAF	Mass Airflow	Air Flow Meter
MAP	Manifold Absolute Pressure	Manifold Pressure Intake Vacuum
MC	Mixture Control	Electric Bleed Air Control Valve (EBCV) Mixture Control Valve (MCV) Electric Air Control Valve (EACV)
MDP	Manifold Differential Pressure	–
MFI	Multiport Fuel Injection	Electronic Fuel Injection (EFI)
MIL	Malfunction Indicator Lamp	Check Engine Lamp
MST	Manifold Surface Temperature	–
MVZ	Manifold Vacuum Zone	–
NVRAM	Non-Volatile Random Access Memory	–
O2S	Oxygen Sensor	Oxygen Sensor, O ₂ Sensor (O ₂ S)
OBD	On-Board Diagnostic	On-Board Diagnostic System (OBD)
OC	Oxidation Catalytic Converter	Oxidation Catalyst Convert (OC), CCo
OL	Open Loop	Open Loop
PAIR	Pulsed Secondary Air Injection	Air Suction (AS)
PCM	Powertrain Control Module	–
PNP	Park/Neutral Position	–
PROM	Programmable Read Only Memory	–
PSP	Power Steering Pressure	–
PTOX	Periodic Trap Oxidizer	Diesel Particulate Filter (DPF) Diesel Particulate Trap (DPT)
RAM	Random Access Memory	Random Access Memory (RAM)
RM	Relay Module	–
ROM	Read Only Memory	Read Only Memory (ROM)
RPM	Engine Speed	Engine Speed
SC	Supercharger	Supercharger
SCB	Supercharger Bypass	E-ABV
SFI	Sequential Multiport Fuel Injection	Electronic Fuel Injection (EFI), Sequential Injection
SPL	Smoke Puff Limiter	–
SRI	Service Reminder Indicator	–
SRT	System Readiness Test	–
ST	Scan Tool	–
TB	Throttle Body	Throttle Body
TBI	Throttle Body Fuel Injection	Single Point Injection Central Fuel Injection (Ci)
TC	Turbocharger	Turbocharger
TCC	Torque Converter Clutch	Torque Converter

TCM	Transmission Control Module	Transmission ECU, ECT ECU
TP	Throttle Position	Throttle Position
TR	Transmission Range	–
TVV	Thermal Vacuum Valve	Bimetallic Vacuum Switching Valve (BVSV) Thermostatic Vacuum Switching Valve (TVSV)
TWC	Three-Way Catalytic Converter	Three-Way Catalytic (TWC) Manifold Converter CC _{RO}
TWC+OC	Three-Way + Oxidation Catalytic Converter	CC _R + CCo
VAF	Volume Airflow	Air Flow Meter
VR	Voltage Regulator	Voltage Regulator
VSS	Vehicle Speed Sensor	Vehicle Speed Sensor
WOT	Wide Open Throttle	Full Throttle
WU-OC	Warm Up Oxidation Catalytic Converter	–
WU-TWC	Warm Up Three-Way Catalytic Converter	–
3GR	Third Gear	–
4GR	Fourth Gear	–